

PRATICO END LIFT UP QUEEN BED

Simple Assembly Instruction - Please keep for future reference

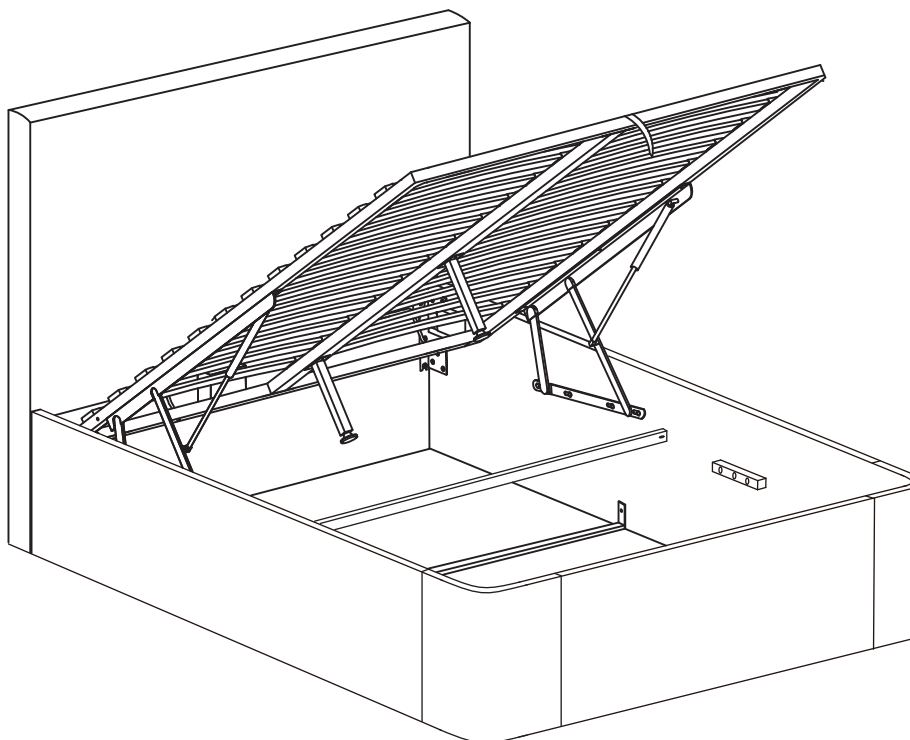

IMPORTANT

- 1) Read these instruction carefully and familiarise yourself with the procedure before assembling the unit.
- 2) Check that you have all the component parts following the list on the back cover and familiarise yourself with each part before proceeding.
- 3) Take all the fitting out of the plastic bag and separate them into their groups.
- 4) Ensure you have enough space to layout all the parts before assembly.
- 5) To avoid scratching it is recommended that you assemble the unit on a soft level surface.

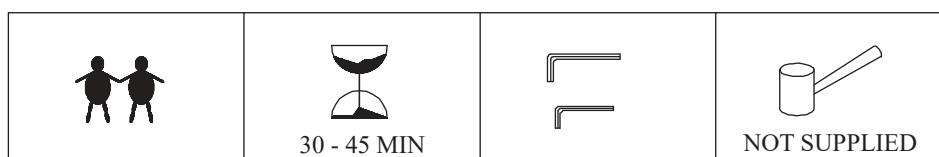

TWO PEOPLE ARE NEEDED TO ASSEMBLY THIS BED.

WE STRONGLY RECOMMEND THAT YOU **DO NOT** USE POWER TOOLS DURING ASSEMBLY. POWER TOOLS CAN OVERTIGHTEN AND **DAMAGE COMPONENTS** OR MAKE THE **PRODUCT UNSAFE**. AND DAMAGE DUE TO THE USE OF POWER TOOLS ARE AT THE CUSTOMERS OWN RISK AND WILL NOT BE ACCEPTED BACK BY THE SUPPLIER. WE RECOMMEND YOU USE THE TOOLS PROVIDED IN YOUR ASSEMBLY KIT.

COMPONENTS

01 1 X LONG METAL FRAME - R



10 2 X MECHANISM

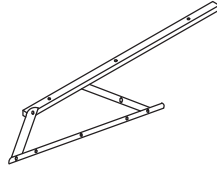

16 1 X SIDE RAIL 'L'

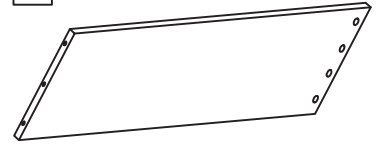

02 1 X LONG METAL FRAME - L



17 1 X CORNER 'R'



03 2 X SHORT METAL FRAME



11 24 X SPRING SLAT



18 1 X CORNER 'L'

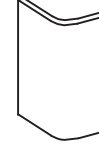

04 1 X CENTER RAIL



12 1 X BLACK WOVEN FABRIC



19 1 X CENTER WOOD



05 2 X SUPPORT LEG

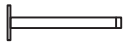

13 1 X HEADBOARD

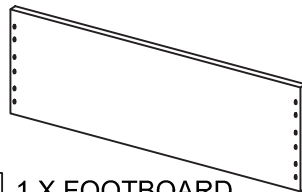

20 3 X BACK LEG

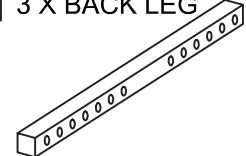

06 1 X SUPPORT RAIL



14 1 X FOOTBOARD



21 2 X SUPPORT WOOD



07 2 X MATTRESS BLOCKER



15 1 X SIDE RAIL 'R'

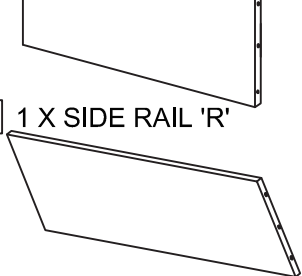

22 1 X HEAD PANEL

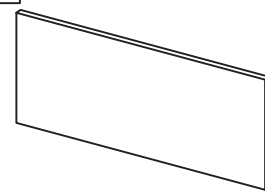

08 2 X CORNER PLATE

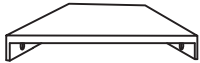

09 2 X GAS PUMP

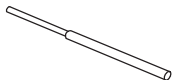

FITTINGS

<p>A</p> <p>SCREW M8 x 20MM</p> <p>4 PCS</p>	<p>B</p> <p>SCREW M8 x 40MM</p> <p>12 PCS</p>	<p>C</p> <p>SCREW M8 x 50MM</p> <p>2 PCS</p>	<p>D</p> <p>WASHER 8 x 16MM</p> <p>18 PCS</p>	<p>E</p> <p>NUT</p> <p>12 PCS</p>
<p>F</p> <p>LOCK NUT</p> <p>4 PCS</p>	<p>G</p> <p>SIDE SLAT STOPPER</p> <p>24 PCS</p>	<p>H</p> <p>CENTER SLAT STOPPER</p> <p>12 PCS</p>	<p>I</p> <p>ALLEN KEY M5</p> <p>1 PCS</p>	<p>J</p> <p>SPANNER</p> <p>1 PCS</p>
<p>K</p> <p>STRAP</p> <p>1 PCS</p>	<p>L</p> <p>SCREW M6 x 60MM</p> <p>32 PCS</p>	<p>M</p> <p>SCREW M6 x 16MM</p> <p>8 PCS</p>	<p>N</p> <p>SCREW M8 x 16MM</p> <p>24 PCS</p>	<p>O</p> <p>BARREL NUT</p> <p>8 PCS</p>
<p>P</p> <p>M10 x 30MM</p> <p>40 PCS</p>	<p>Q</p> <p>SCREW M4 x 30MM</p> <p>8 PCS</p>	<p>R</p> <p>PAN SCREW M4 x 16MM</p> <p>2 PCS</p>	<p>S</p> <p>SCREW M4 x 16MM</p> <p>40 PCS</p>	<p>T</p> <p>ALLEN KEY M4</p> <p>1 PCS</p>
<p>U</p> <p>BRACKET 'L'</p> <p>4 PCS</p>	<p>V</p> <p>BRACKET 'R'</p> <p>4 PCS</p>	<p>W</p> <p>WASHER 6 x 13MM</p> <p>56 PCS</p>		

STEP 1

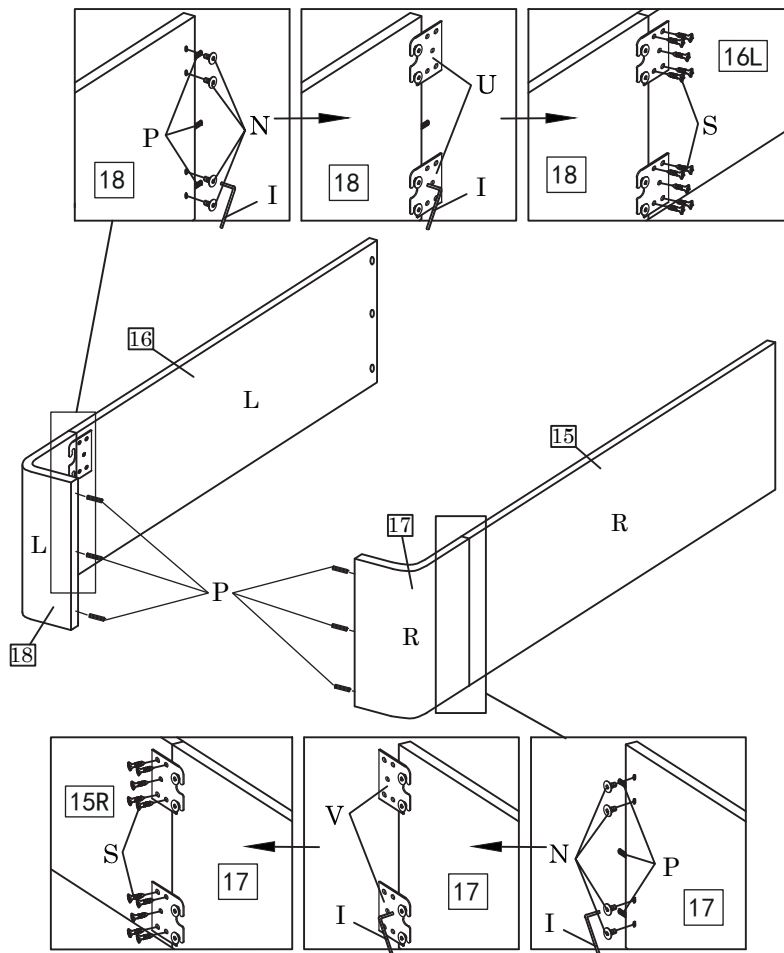

N		8 PCS
P		12 PCS
I		1 PCS
U		2 PCS
V		2 PCS
S		20 PCS

STEP 2

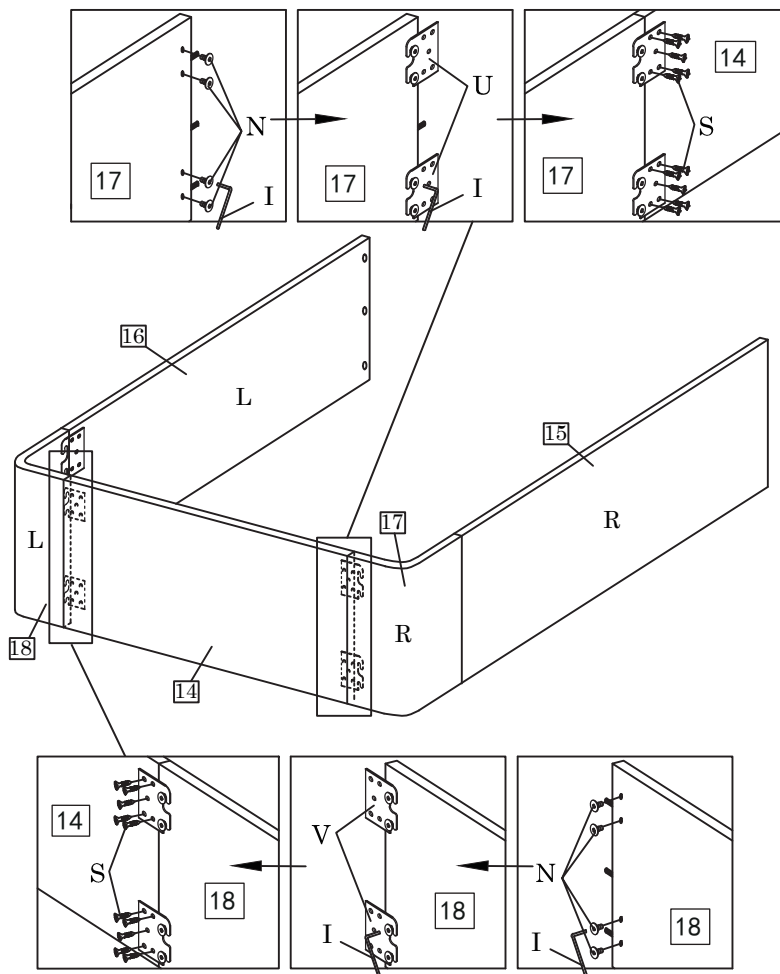

N		8 PCS
I		1 PCS
U		2 PCS
V		2 PCS
S		20 PCS

STEP 3

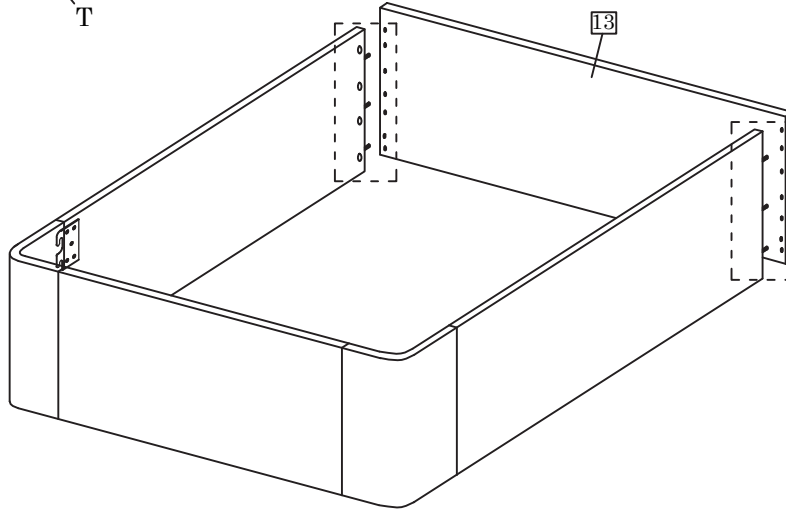
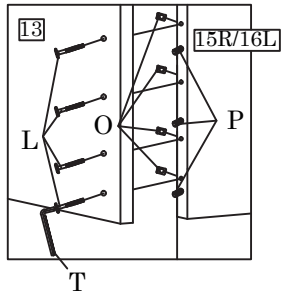

L		M6 x 60mm	8 PCS
O		Barret Nut	8 PCS
P		M10 x 30mm	6 PCS
T		M4 Allen Key	1 PCS

STEP 4

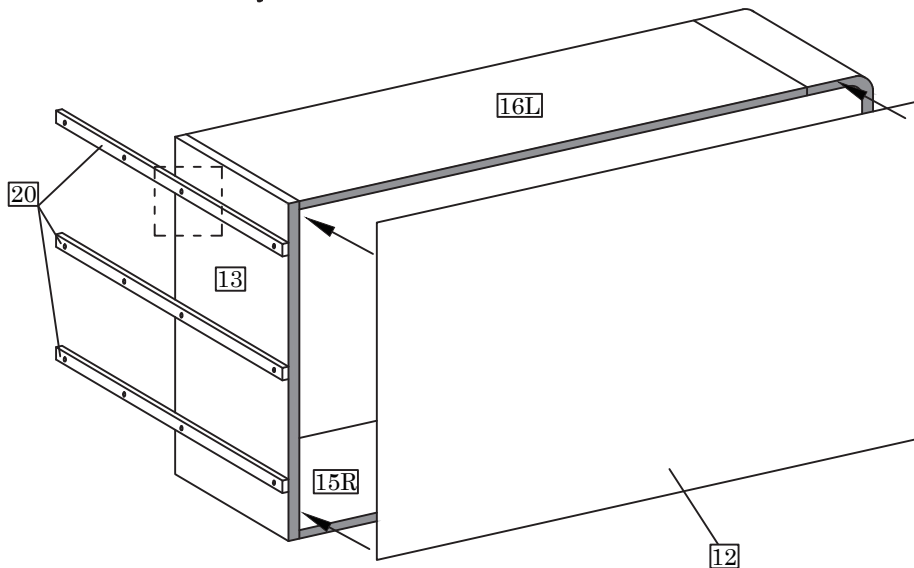
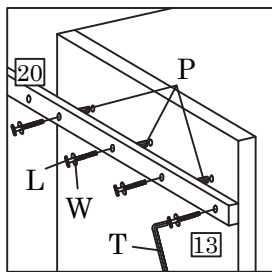

L		M6 x 60mm	12 PCS
W		Washer 6 x 13mm	12 PCS
P		M10 x 30mm	9 PCS
T		M4 Allen Key	1 PCS

STEP 5

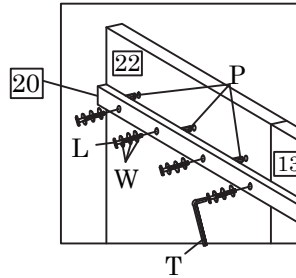
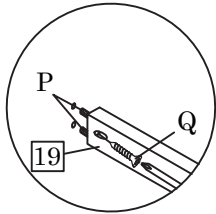
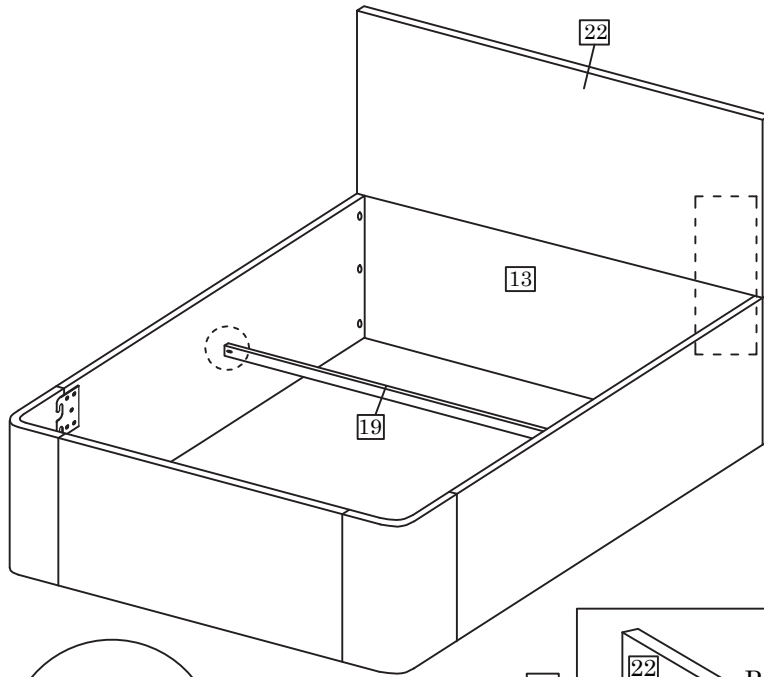

L		M6 x 60mm	12 PCS
W		Washer 6 x 13mm	36 PCS
P		M10 x 30mm	13 PCS
Q		M4 x 30mm	2 PCS
T		M4 Allen Key	1 PCS

STEP 6

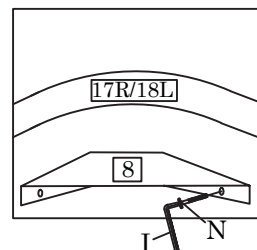
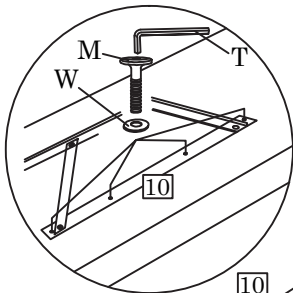
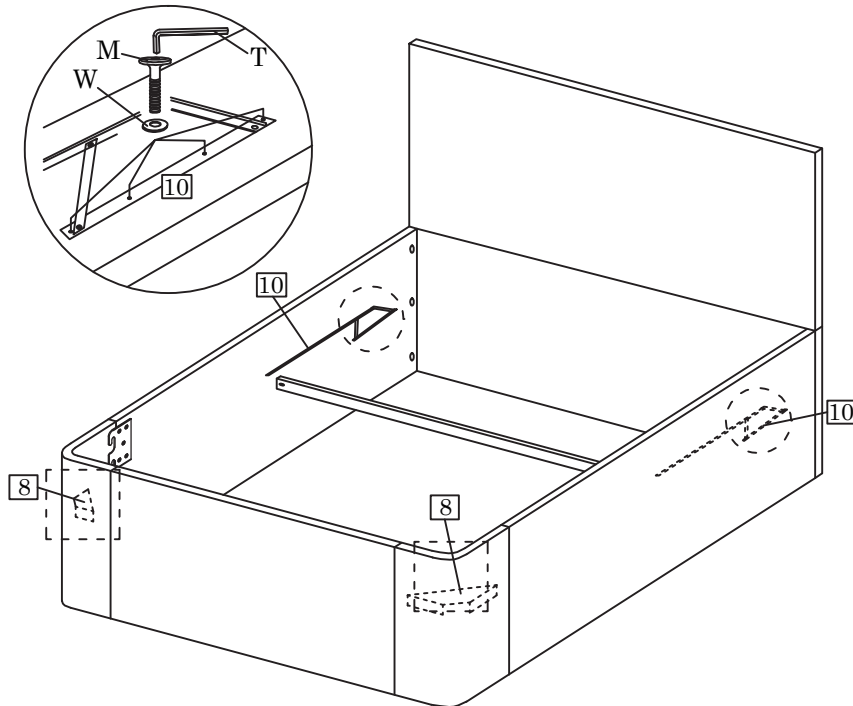

W		Washer 6 x 13mm	8 PCS
M		M6 x 16mm	8 PCS
N		M8 x 16mm	8 PCS
I		M5 Allen Key	1 PCS
T		M4 Allen Key	1 PCS

STEP 7

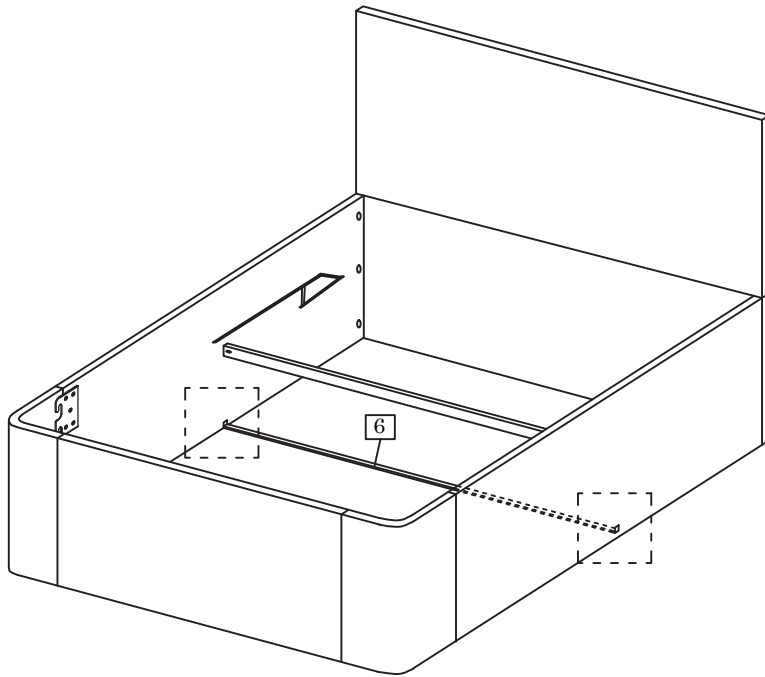



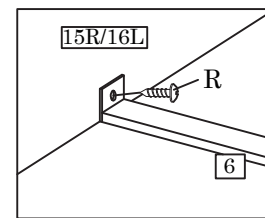

R	
Pan Screw M4 x 16mm	
2 PCS	

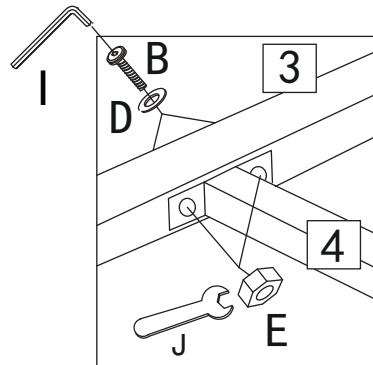
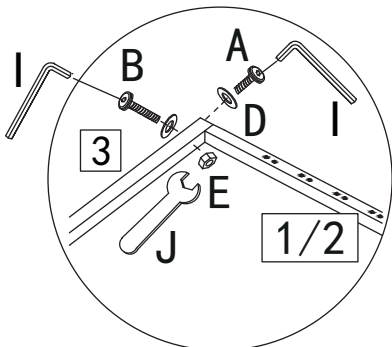
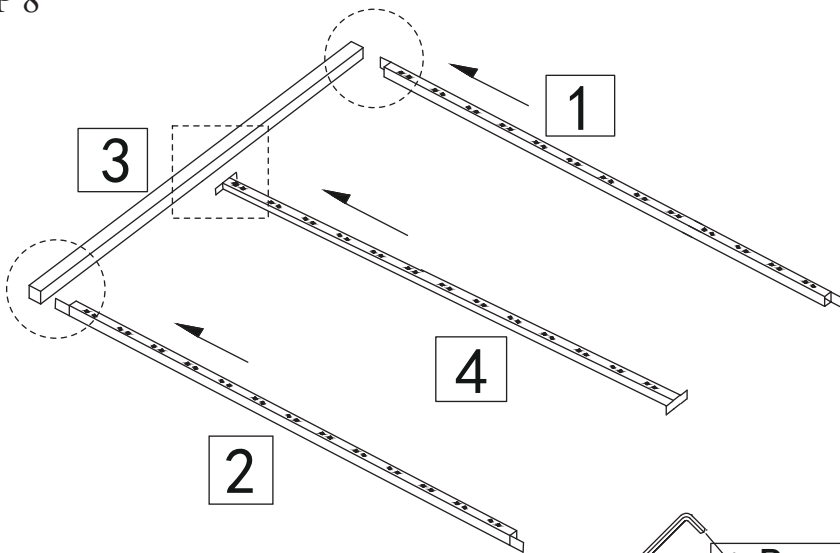

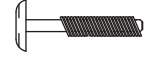
STEP 8

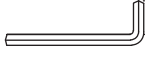

A	
SCREW M8 x 20MM	
2 PCS	
B	
SCREW M8 x 40MM	
4 PCS	
E	
NUT	
4 PCS	
D	
WASHER 8 x 16MM	
6 PCS	
J	
SPANNER	
1 PCS	
I	
M5 Allen Key	
1 PCS	

STEP 9

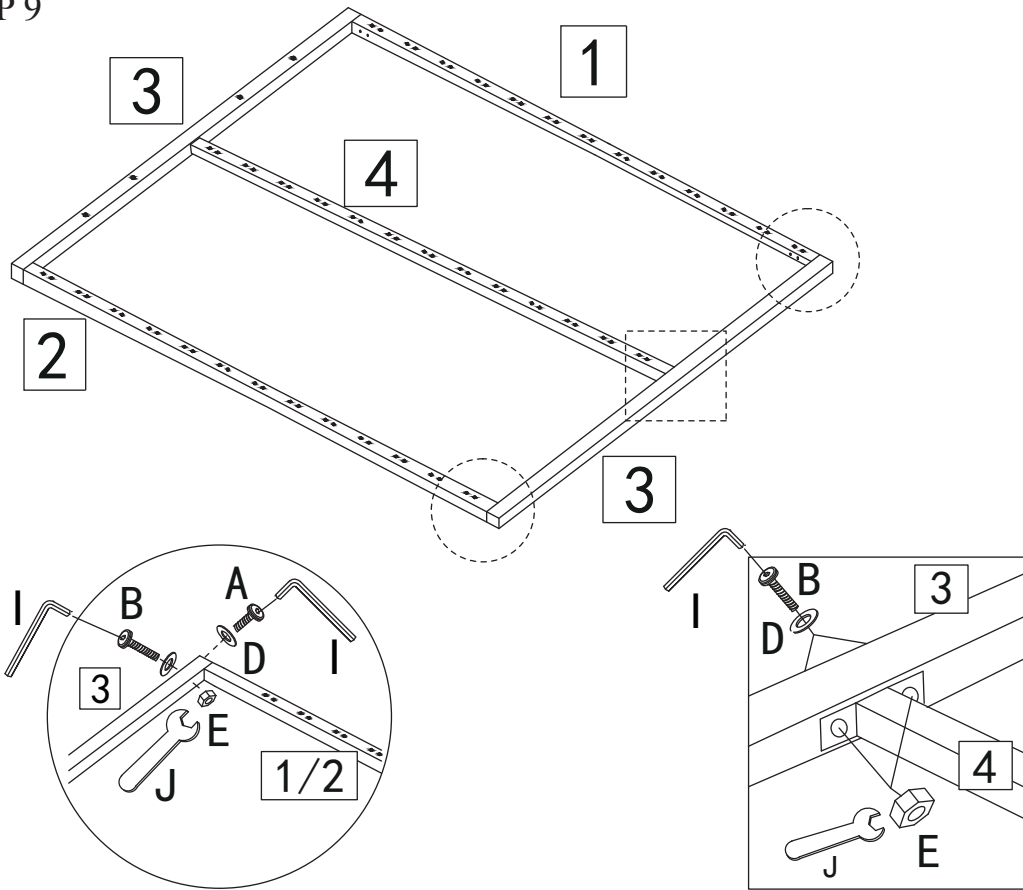

A		2 PCS
SCREW M8 x 20MM		
B		4 PCS
SCREW M8 x 40MM		
E		4 PCS
NUT		
D		6 PCS
WASHER 8 x 16MM		
J		1 PCS
SPANNER		
I		1 PCS
M5 Allen Key		

STEP 10

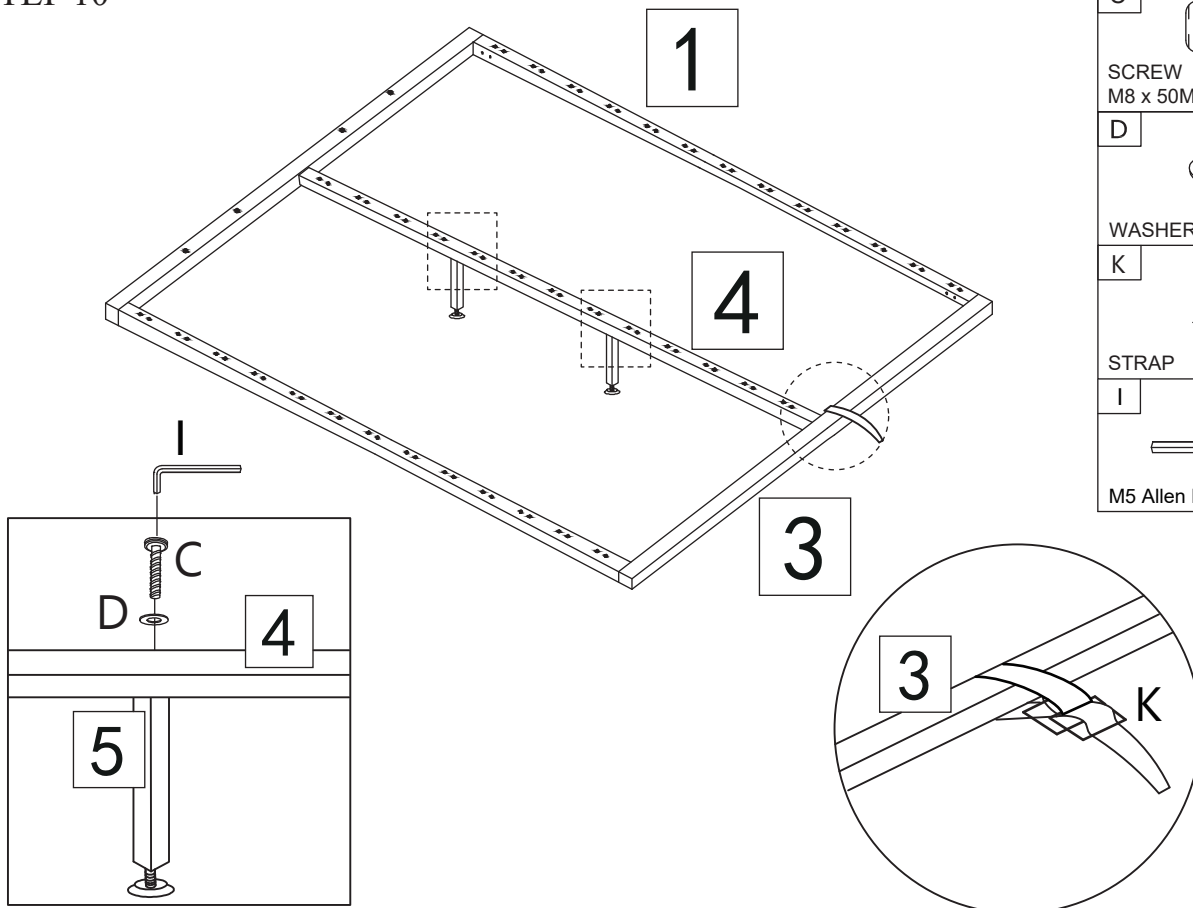

C		2 PCS
SCREW M8 x 50MM		
D		2 PCS
WASHER 8 x 16MM		
K		1 PCS
STRAP		
I		1 PCS
M5 Allen Key		

STEP 11

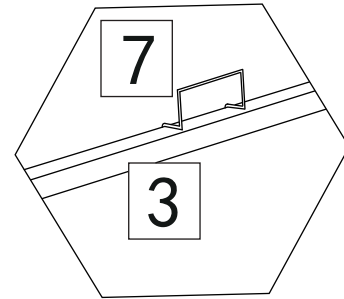
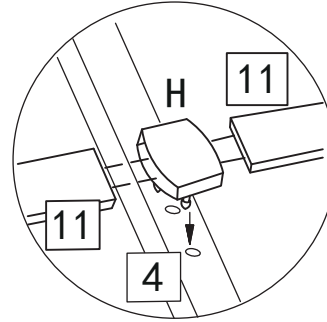
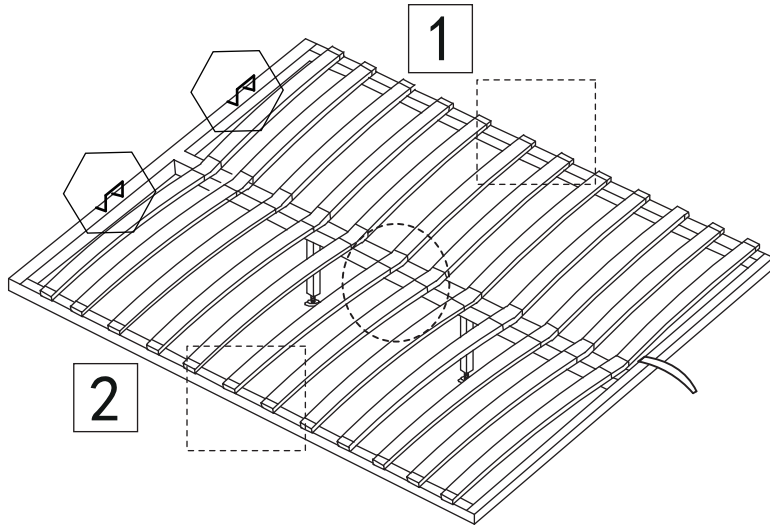
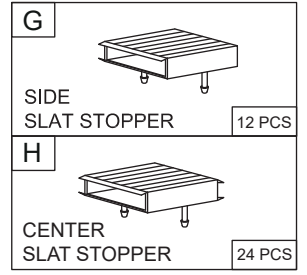
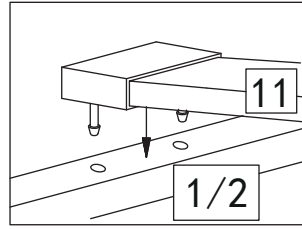
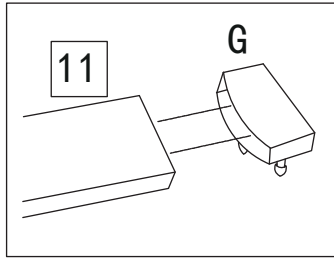

STEP 12

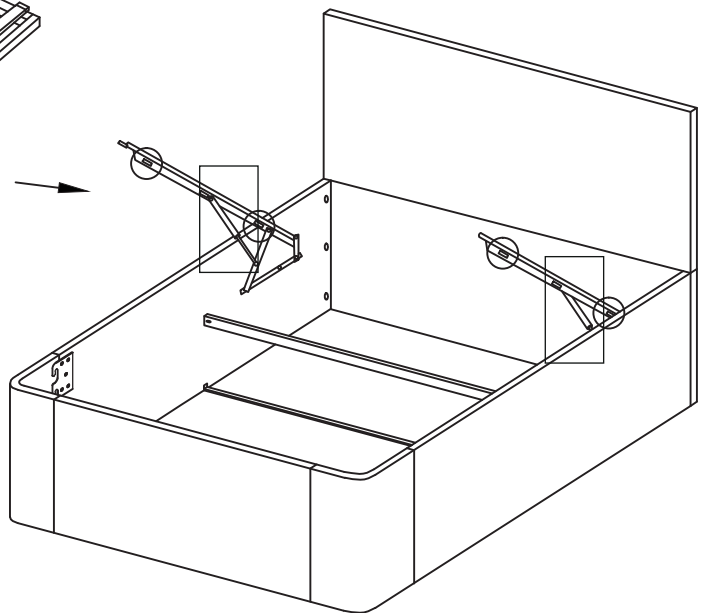
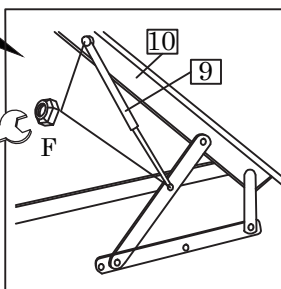
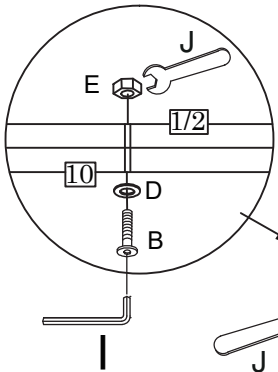
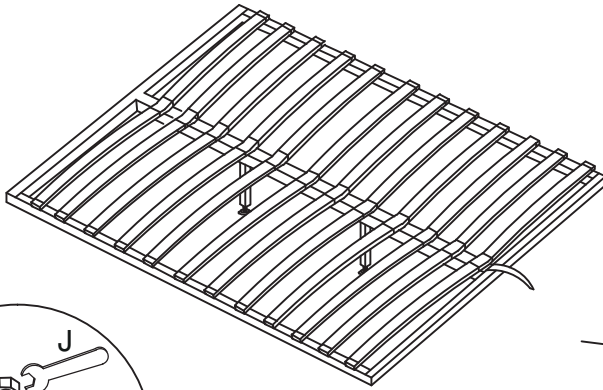
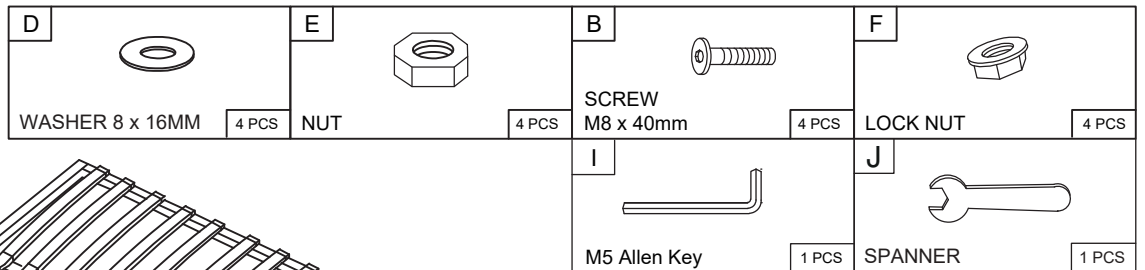

STEP 13

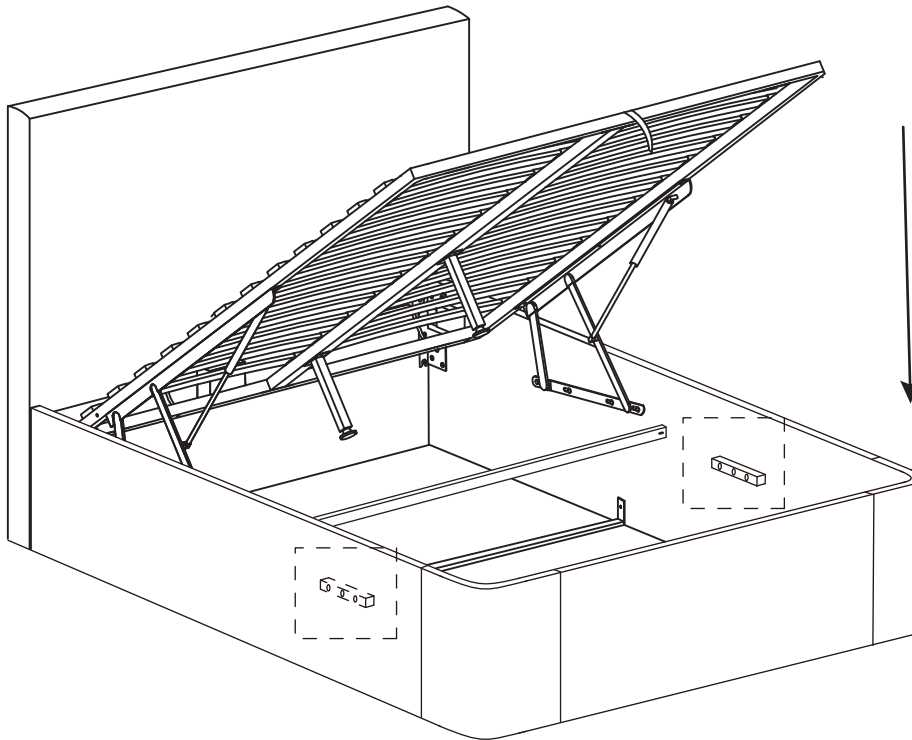
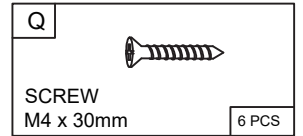

1. Lower down the base.
2. Mark the position of bottom of base
3. Assemble the Support wood, make sure it is right under the base frame, for better support.

