

REVEAL QUEEN BED

Simple Assembly Instruction - Please keep for future reference

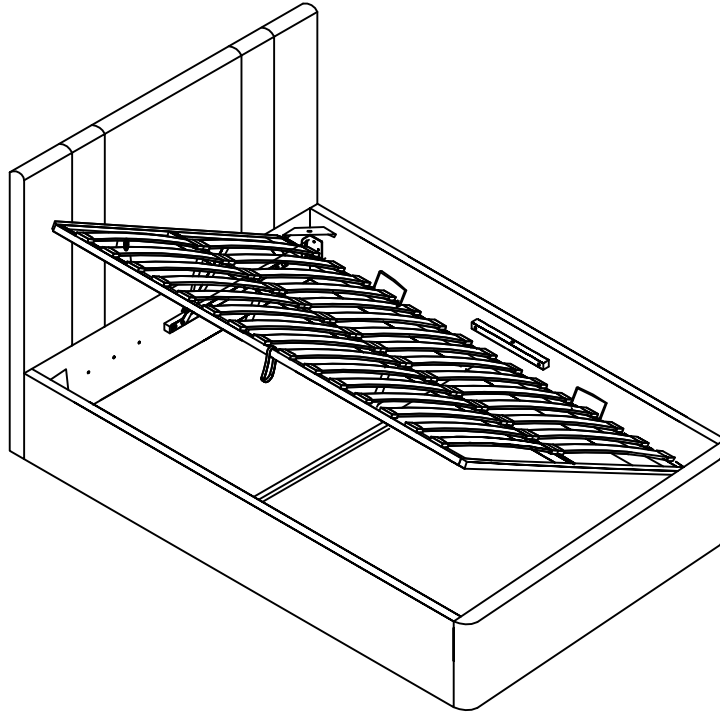

IMPORTANT

- 1) Read these instruction carefully and familiarise yourself with the procedure before assembling the unit.
- 2) Check that you have all the component parts following the list on the back cover and familiarise yourself with each part before proceeding.
- 3) Take all the fitting out of the plastic bag and separate them into their groups.
- 4) Ensure you have enough space to layout all the parts before assembly.
- 5) To avoid scratching it is recommended that you assemble the unit on a soft level surface.

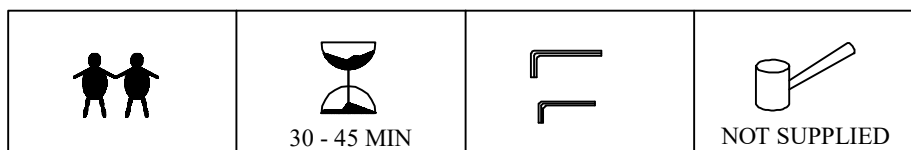

TWO PEOPLE ARE NEEDED TO ASSEMBLY THIS BED.

WE STRONGLY RECOMMEND THAT YOU **DO NOT** USE POWER TOOLS DURING ASSEMBLY. POWER TOOLS CAN OVERTIGHTEN AND **DAMAGE COMPONENTS** OR MAKE THE **PRODUCT UNSAFE**. AND DAMAGE DUE TO THE USE OF POWER TOOLS ARE AT THE CUSTOMERS OWN RISK AND WILL NOT BE ACCEPTED BACK BY THE SUPPLIER. WE RECOMMEND YOU USE THE TOOLS PROVIDED IN YOUR ASSEMBLY KIT.

COMPONENTS

01 1 X HEADBOARD-UPPER



02 1 X HEADBOARD-LOWER

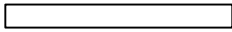

03 1 X FOOTBOARD

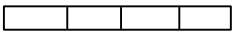

04 2 X SIDE RAILS

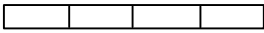

05 1 X BLACK WOVEN FABRIC



06 1 X LONG METAL FRAME - A



07 1 X LONG METAL FRAME - B
(STRAP PRE-FIX)



08 2 X SHORT METAL FRAME

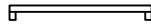

09 1 X CENTER RAIL



10 2 X SUPPORT LEG

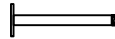

11 1 X SUPPORT RAIL

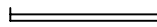

12 2 X MATTRESS BLOCKER



13 4 X CORNER PLATE

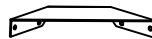

14 2 X GAS PUMP

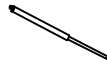

15 2 X MECHANISM

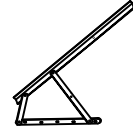

16 26 X SPRING SLAT



















17 4 X LEG



18 2 X HINGE'S SUPPORT
RAILS





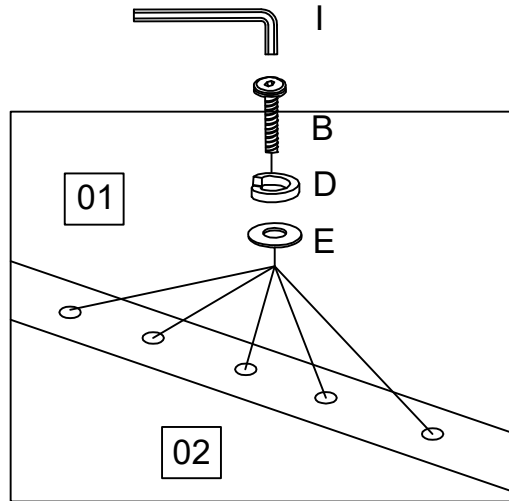
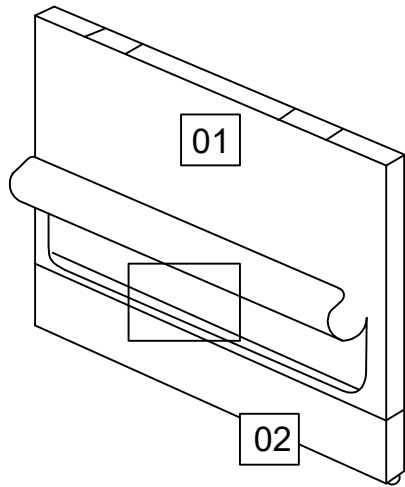

FITTINGS

<p>A</p>  <p>SCREW 5/16 X 25MM</p> <p>20PCS</p>	<p>B</p>  <p>SCREW 5/16 X 45MM</p> <p>19PCS</p>	<p>C</p>  <p>SCREW 1/4 X 57MM</p> <p>8PCS</p>	<p>D</p>  <p>Spring Washer*5/16</p> <p>53PCS</p>	<p>E</p>  <p>Washer*5/16</p> <p>53PCS</p>
<p>F</p>  <p>LOCK NUT</p> <p>4PCS</p>	<p>G</p>  <p>NUT* 5/16</p> <p>14PCS</p>	<p>H</p>  <p>SIDE SLAT STOPPER</p> <p>26PCS</p>	<p>I</p>  <p>ALLEN KEY M5</p> <p>1PC</p>	<p>J</p>  <p>SPANNER</p> <p>1PC</p>
<p>K</p>  <p>WOOD SCREW</p> <p>4PCS</p>	<p>L</p>  <p>SCREW 1/4 X 20MM</p> <p>20PCS</p>	<p>M</p>  <p>CENTER SLAT STOPPER</p> <p>13PCS</p>	<p>N</p>  <p>Spring Washer*1/4</p> <p>28PCS</p>	<p>O</p>  <p>Washer*1/4</p> <p>28PCS</p>
<p>P</p>  <p>ALLEN KEY M4</p> <p>1PC</p>				

STEP 1



B		SCREW 5/16 X 45MM	5PCS
D		Spring Washer*5/16	5PCS
E		Washer*5/16	5PCS
I		ALLEN KEY M5	1PC



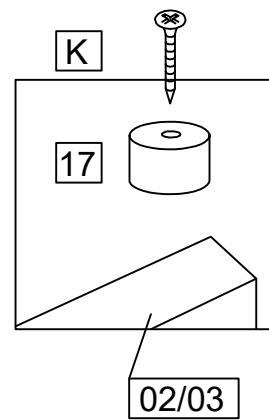
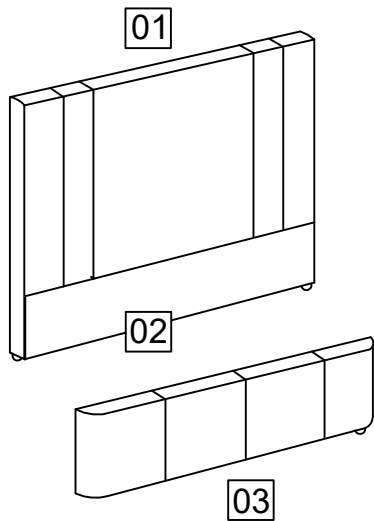

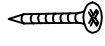
STEP 2

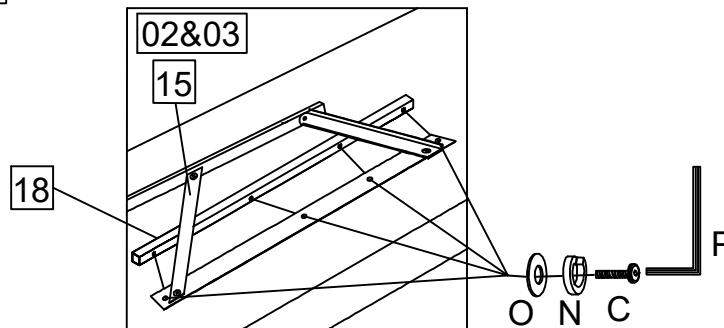
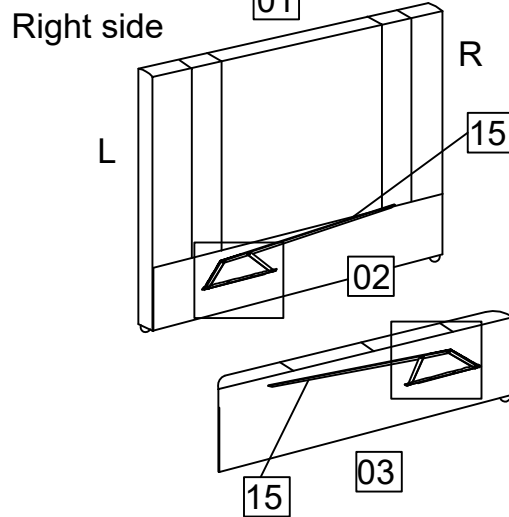
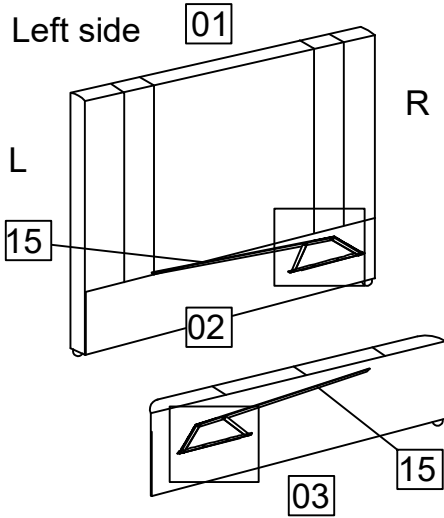

K			4PCS
---	---	--	------





STEP 3 If you want to lift the base from

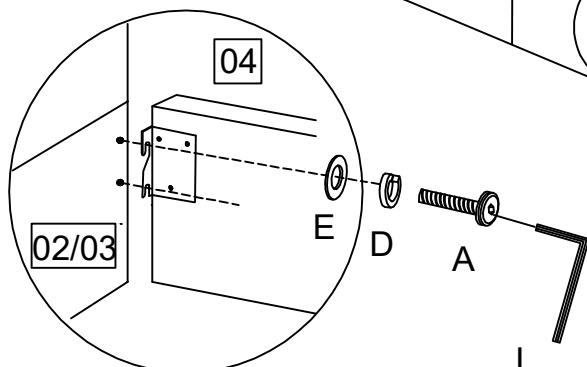
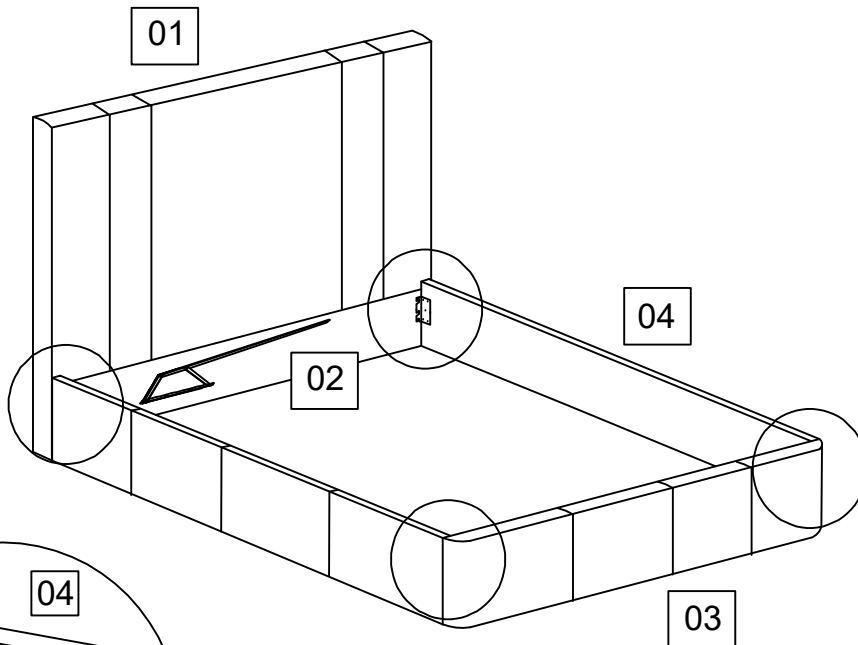

C		SCREW 1/4 X 57MM	8PCS
N		Spring Washer*1/4	8PCS
O		Washer*1/4	8PCS
P		ALLEN KEY M4	1PC

STEP 4



A		SCREW 5/16 X 25MM	8PCS
D		Spring Washer*5/16	8PCS
E		Washer*5/16	8PCS
I		ALLEN KEY M5	1PC

STEP 5

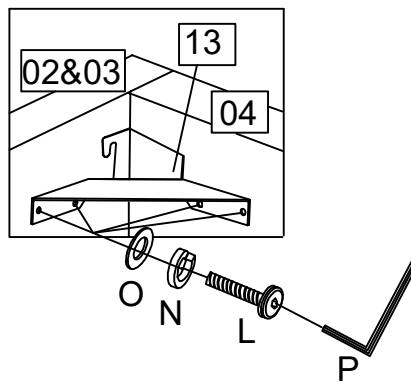
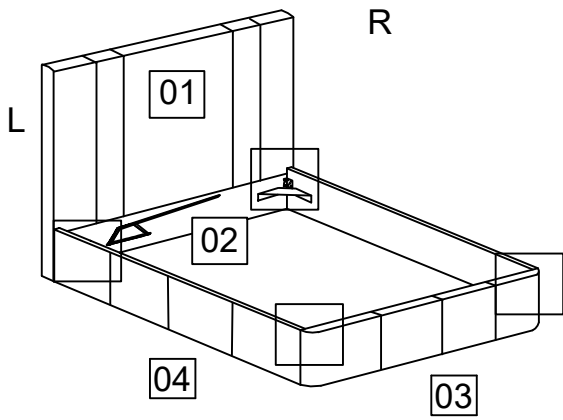

L		SCREW 1/4 X 20MM	16PCS
N		Spring Washer*1/4	16PCS
O		Washer*1/4	16PCS
P		ALLEN KEY M4	1PC

STEP 6

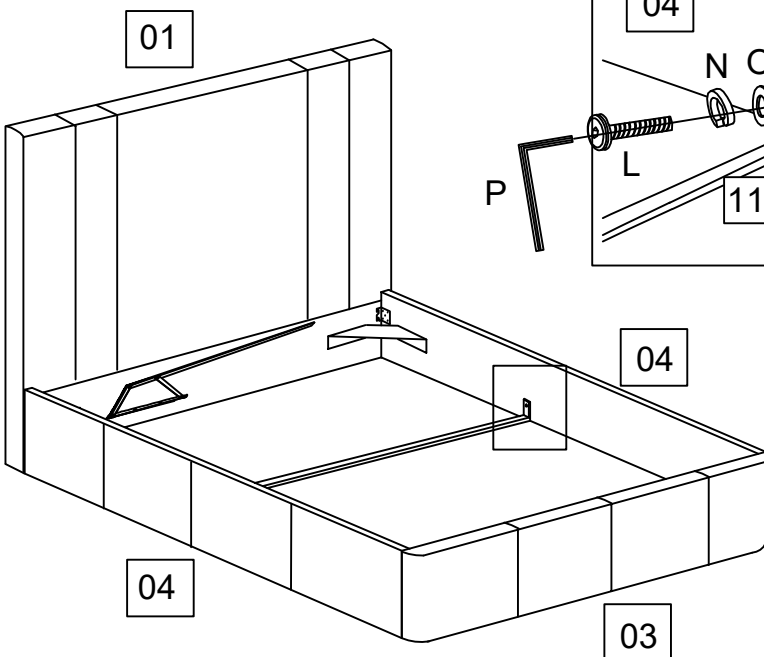



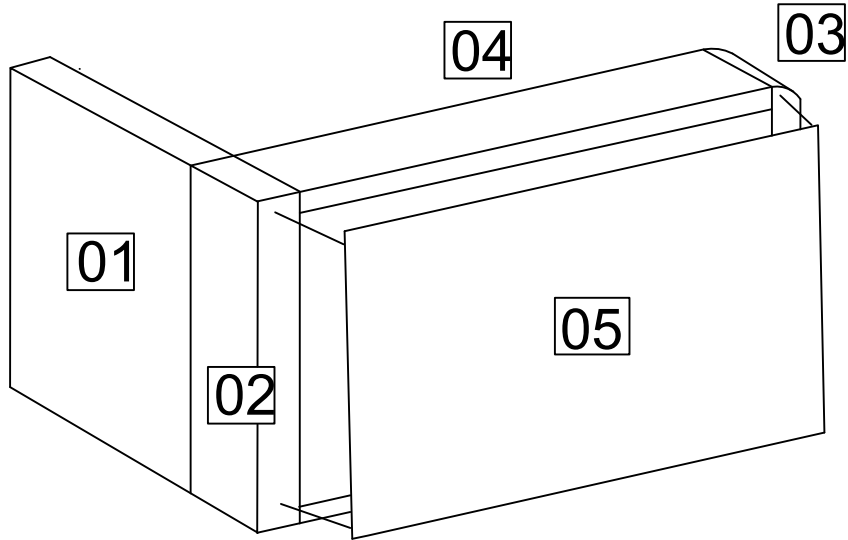

L		SCREW 1/4 X 20MM	4PCS
N		Spring Washer*1/4	4PCS
O		Washer*1/4	4PCS
P		ALLEN KEY M4	1PC

STEP 7

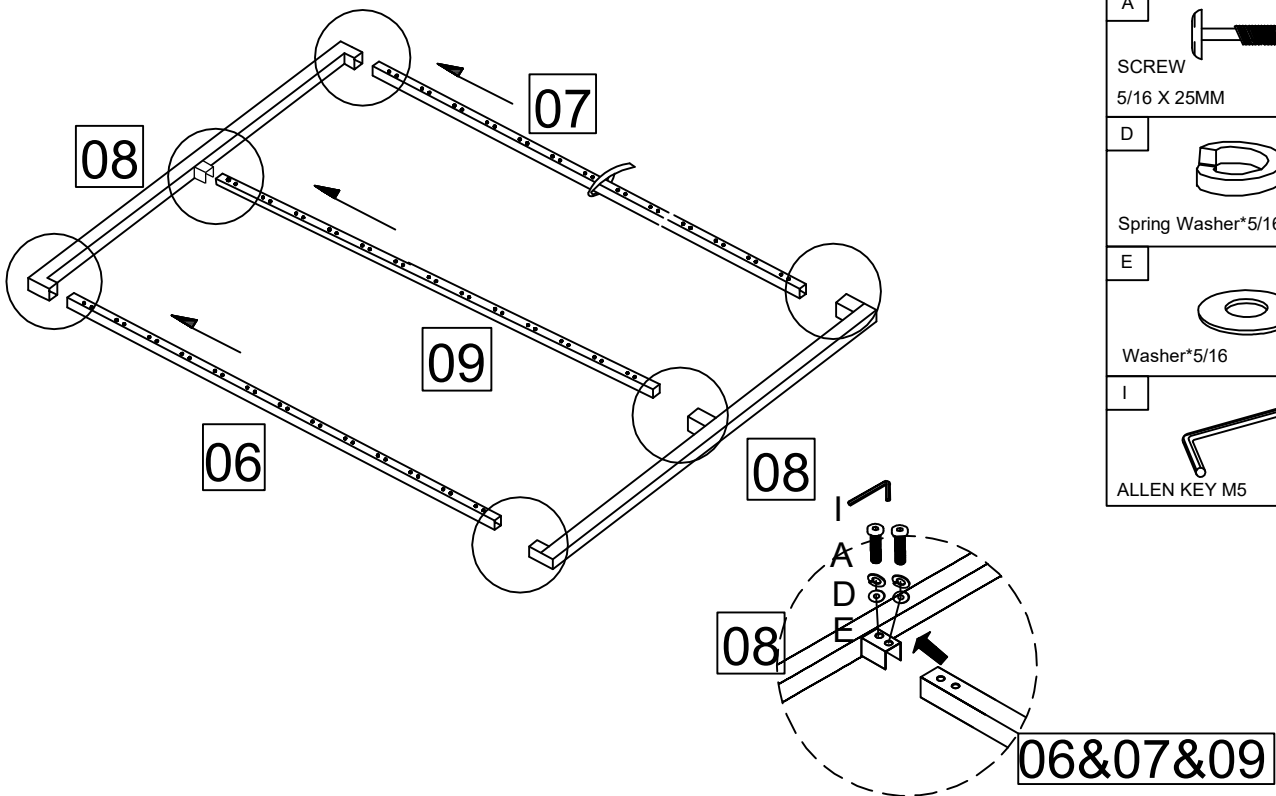

STEP 8



A		12PCS
SCREW 5/16 X 25MM		
D		12PCS
Spring Washer*5/16		
E		12PCS
Washer*5/16		
I		1PC
ALLEN KEY M5		

STEP 9

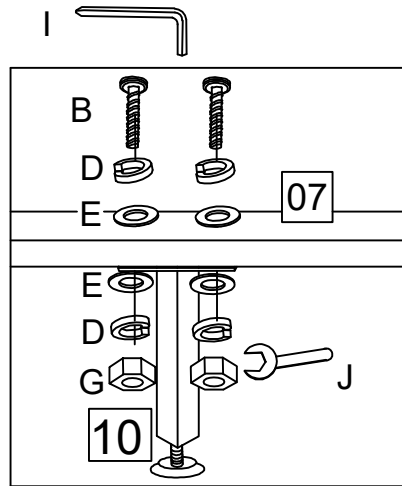
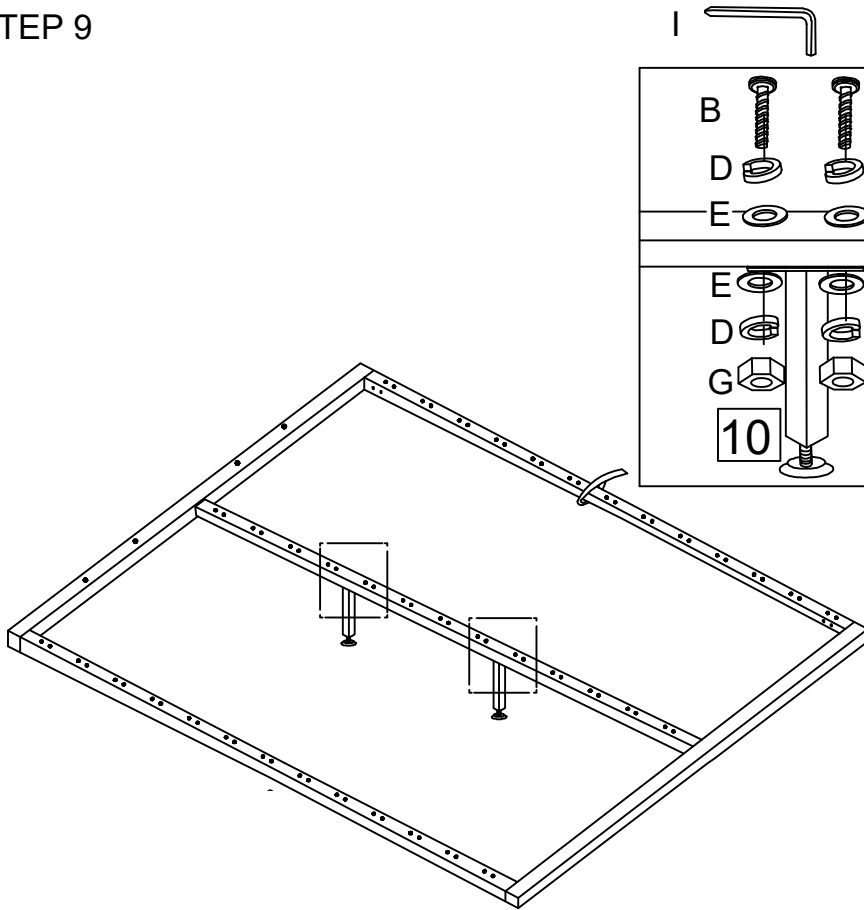

B		SCREW 5/16 X 45MM	4PCS
D		Spring Washer*5/16	8PCS
E		Washer*5/16	8PCS
I		ALLEN KEY M5	1PC
G		NUT* 5/16	4PCS
J		SPANNER	1PC

STEP 10

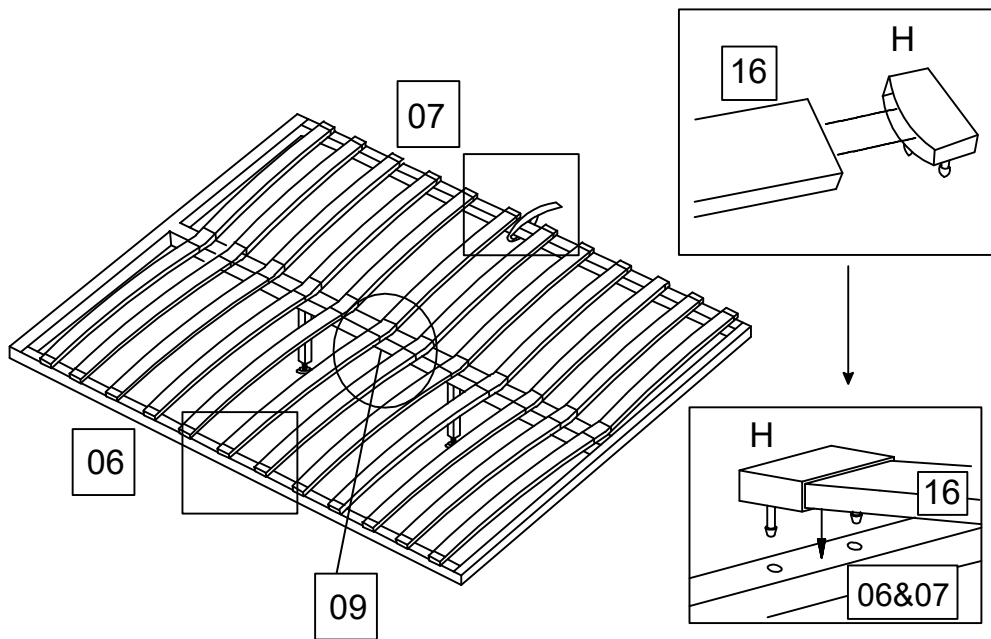

H		SIDE SLAT STOPPER	26PCS
M		CENTER SLAT STOPPER	13PCS

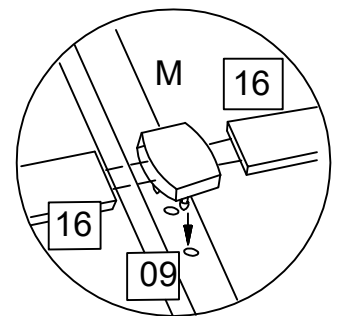

STEP 11

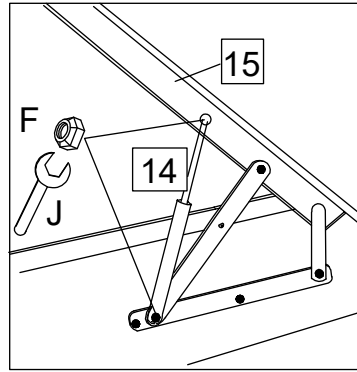
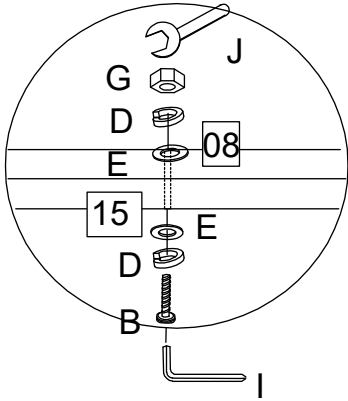

B		SCREW 5/16 X 45MM	6PCS
D		Spring Washer*5/16	12PCS
E		Washer*5/16	12PCS
I		ALLEN KEY M5	1PC
G		NUT* 5/16	6PCS
F		LOCK NUT	4PCS
J		SPANNER	1PC

Left side lift up



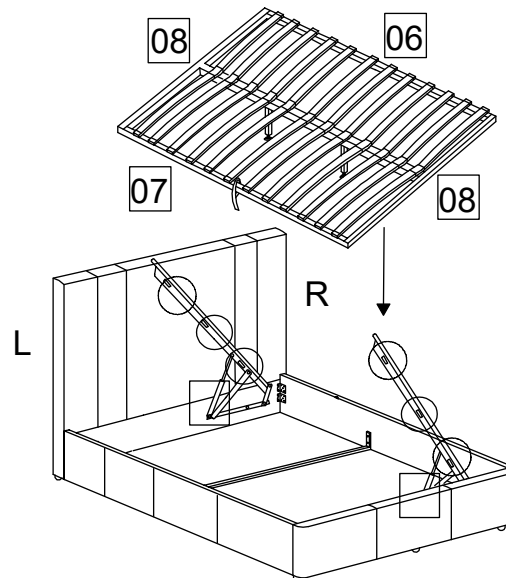
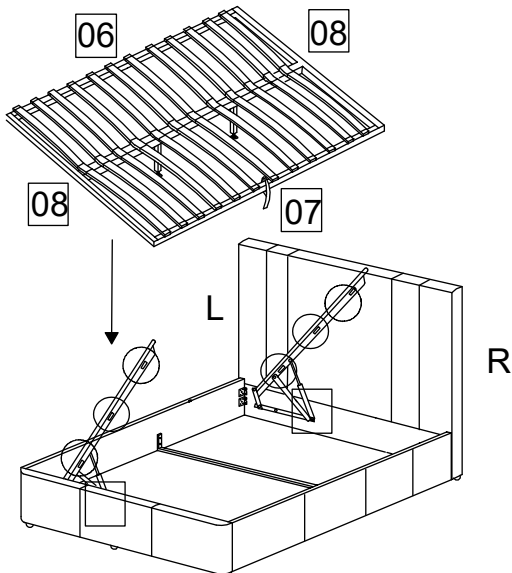



Right side lift up

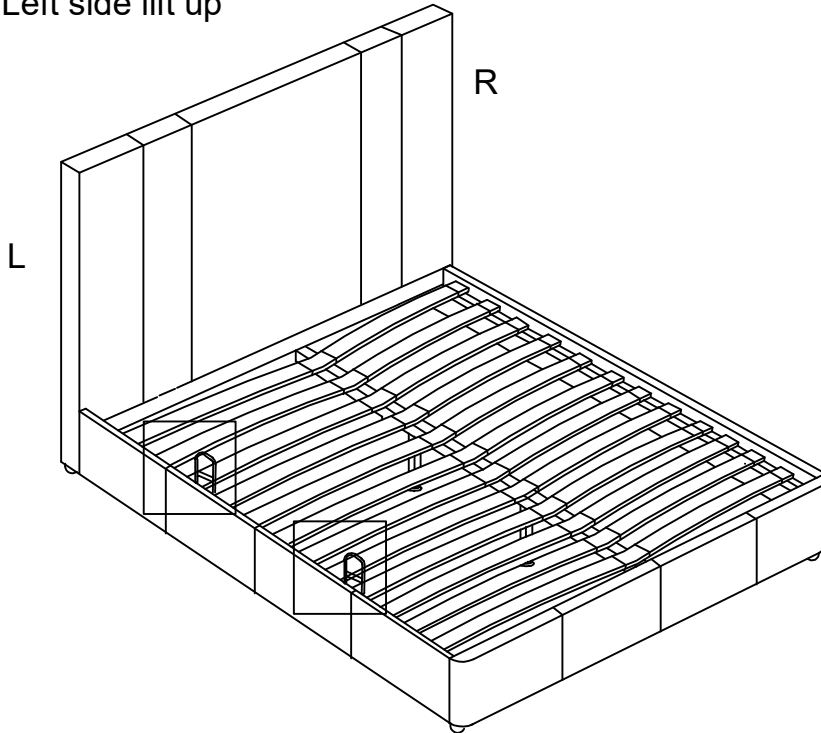

STEP 12

Left side lift up



B		SCREW 5/16 X 45MM	4PCS
D		Spring Washer*5/16	8PCS
E		Washer*5/16	8PCS
I		ALLEN KEY M5	1PC
G		NUT* 5/16	4PCS
J		SPANNER	1PC

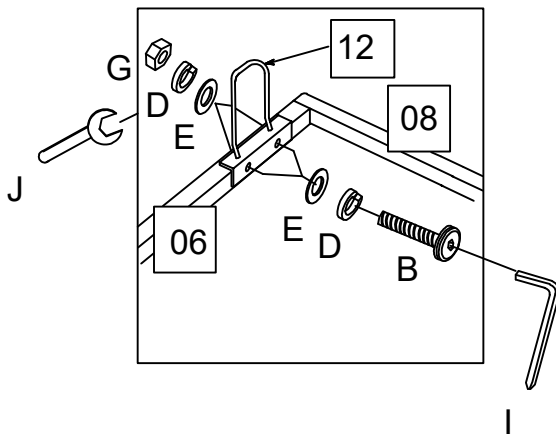

Right side lift up

