



ExpandFurniture.com

## Hover Desk Installation guide

**Tools & Parts that you will need that are not included:**

- Step Ladder, Power Drill/Screw Driver
- Wall Anchors for your wall type: ~12 are recommended with a strength rating of at least 100+ lbs each
- Consider some extra wall brackets x 3 (simple L shape)

**Mattress:** Recommended 50lbs + or you might need lighter pistons.

You should have a mattress before you start the install so you can test it. If you have a light mattress, please contact us before you start in case you need weaker it gets cut off here. Should end with 'weaker pistons.

Expand Furniture Inc declines all liability caused by the incorrect assembly of the bed or failure to mount the bed. If you fail to mount the wall bed to the wall or correctly fasten it, we do not take responsibility for this.

We strongly recommend you watch the online video for key steps like installing the pistons. We have a full video install online:

**Important Notes & Tips for all installs:**

1. Clear your room as much as possible before you start the install. Unpacking the panels will take some time, longer than many expect, so do this in advance of your install. You will need a power drill, screw driver, wall anchors and a ladder.
2. All Hover & MurphySofa are do it yourself assembly and require wall mounts. It is up to you to determine your wall type, make sure it is safe and correctly mount the wall bed to your wall safely and properly. It is best to hit studs if you have drywall and make sure to use the correct wall anchors for your wall type. You can always install extra brackets and anchors for added security and peace of mind. Your local hardware store or your handyman/contractor should be able to advise on this.
3. Once you install the pistons there will be strong tension on the bed frame. This is normal! After you have the face panel and the mattress the weight will be correct, and it will work properly with normal tension. **For this portion the metal frame should not be flush, but it should go beyond flush (+3-5 inches) pushing inside the bed.** After you add on the face panel and mattress it will move closer to flush and there will be 'soft stoppers' to hold it in place flush.
4. The Face Panel Clips that join the face panel to the bed frame might need some minor adjusting. Install 1 face panel at a time and make sure it looks straight. Adjust if needed.
5. Test both face panels by raising the bed up and making sure they look good before drilling in the face panel to the frame. Make sure there is good inwards pressure on the frame.
6. We suggest drilling every 2nd hole on the face panels so you have the ability to use fresh holes for a future adjustment. (Back panel b2/b3 connection also does not need every hole with a screw, just spread them evenly until you have used them all)
7. If you get stuck call or email us or hire a professional to finish off the job: <https://expandfurniture.com/contact/>

# LIST OF PARTS

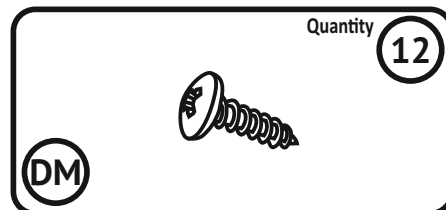
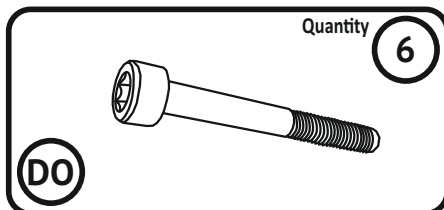
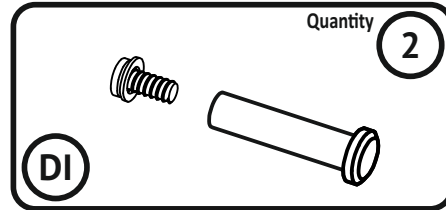
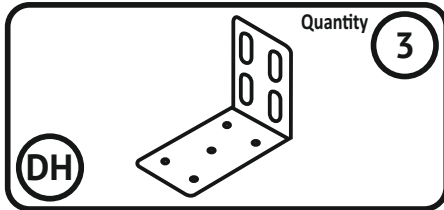
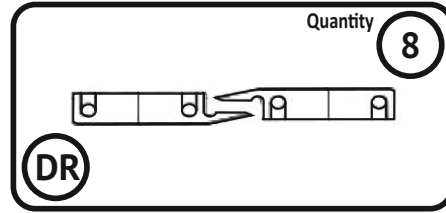
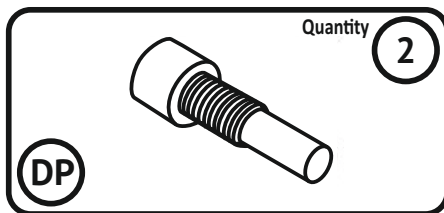
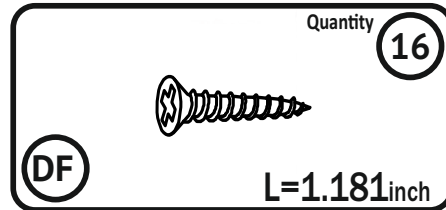
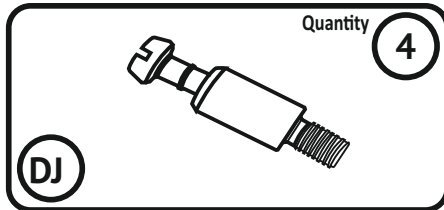
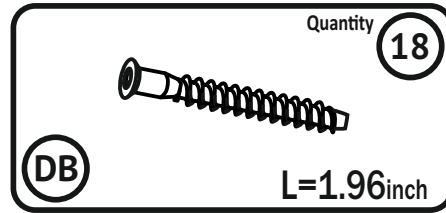
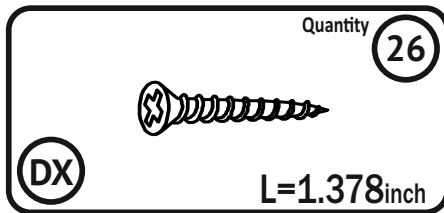
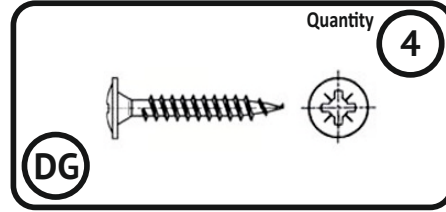
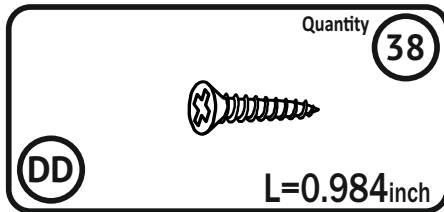
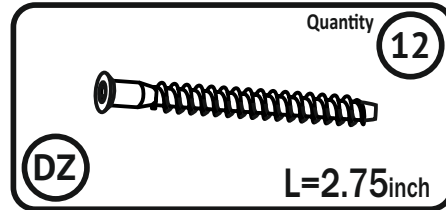
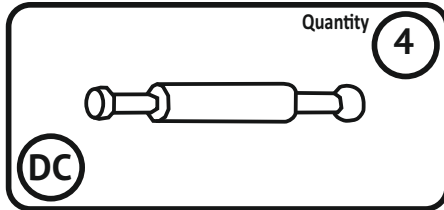
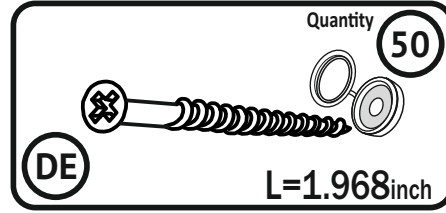
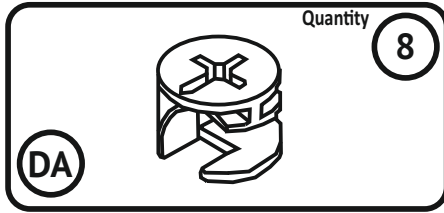

# LIST OF PARTS

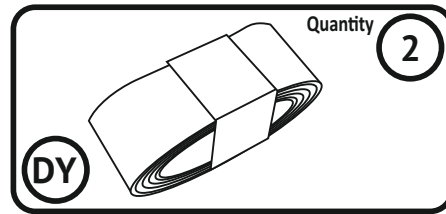
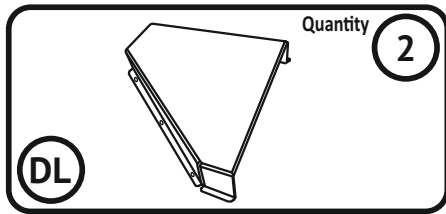
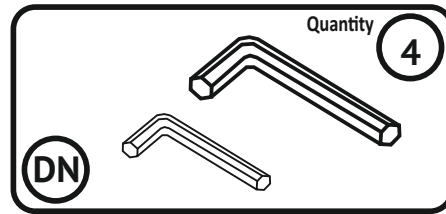
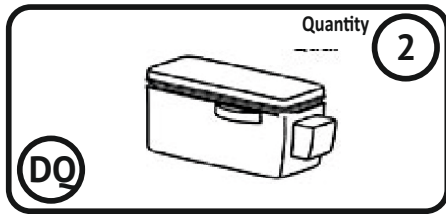
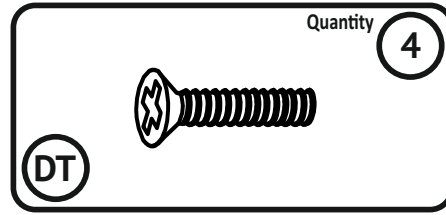
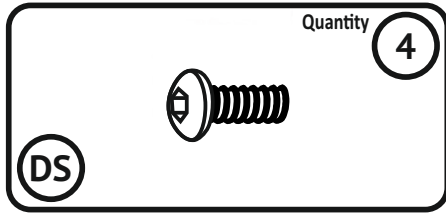

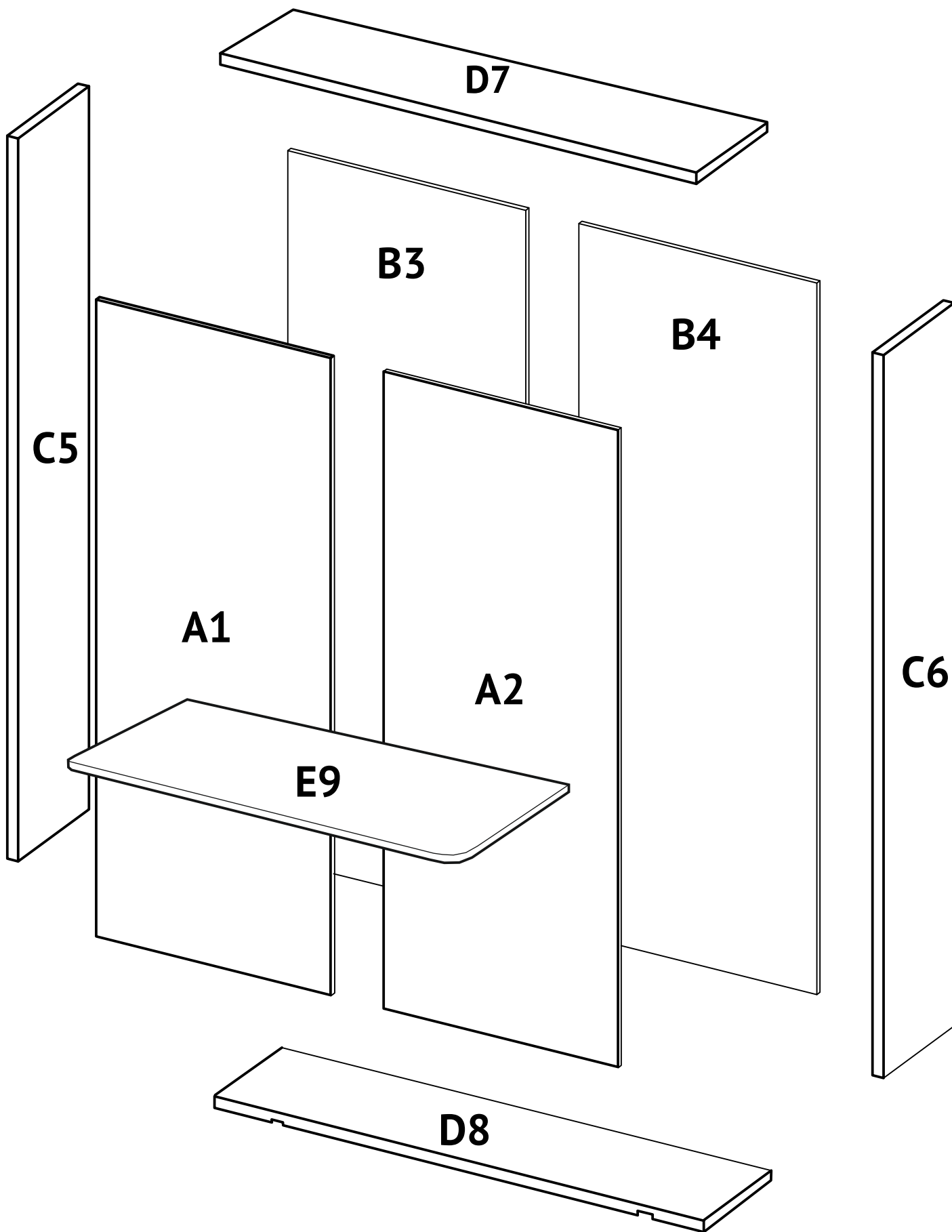

*For some finishes there is a protective plastic film over the panels. We suggest removing the inside protective plastic film layer before installing the panels.*

*You can leave the outside protective layer on until the end if you like, or remove it now.*

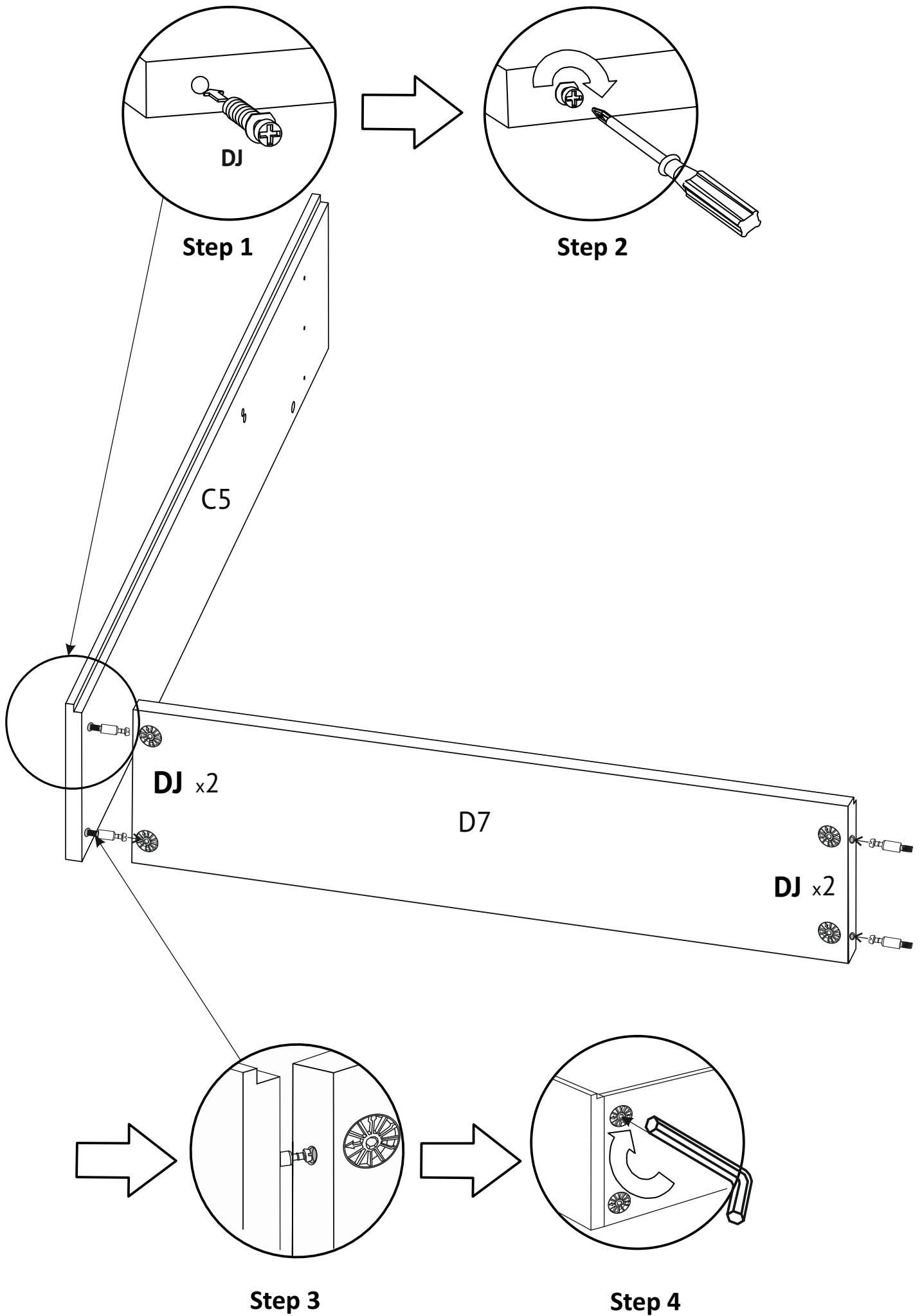

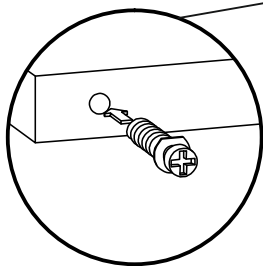
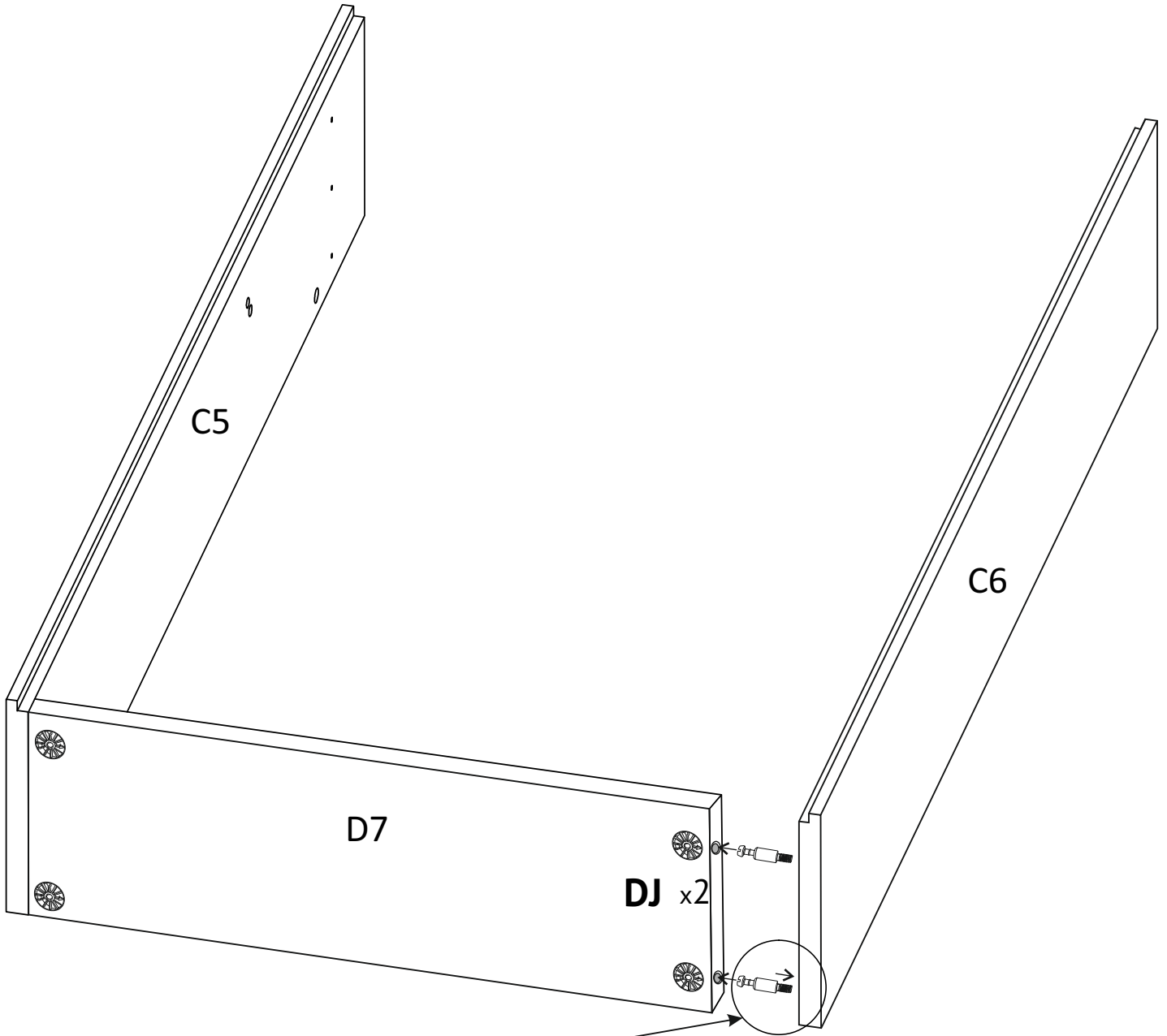

**Step 1**

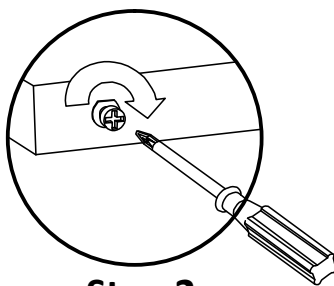
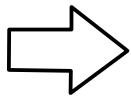

**Step 2**

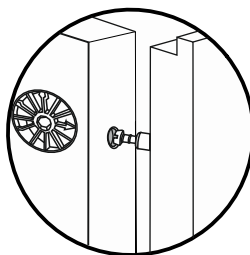

**Step 3**

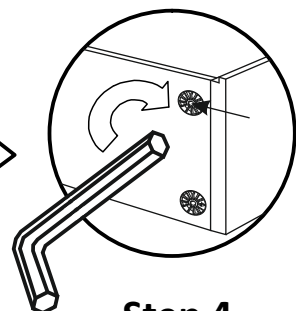
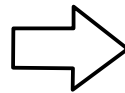

**Step 4**

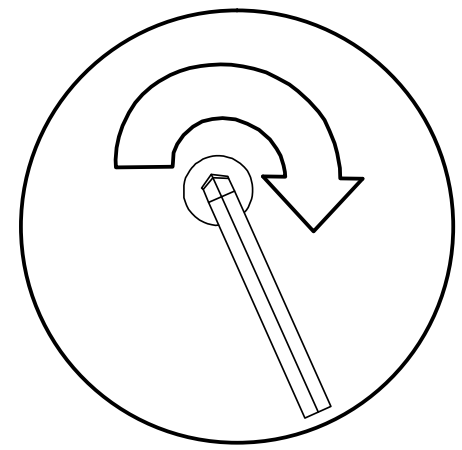
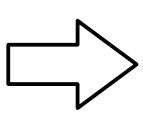
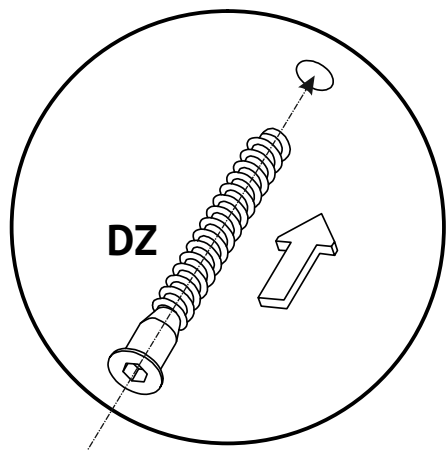
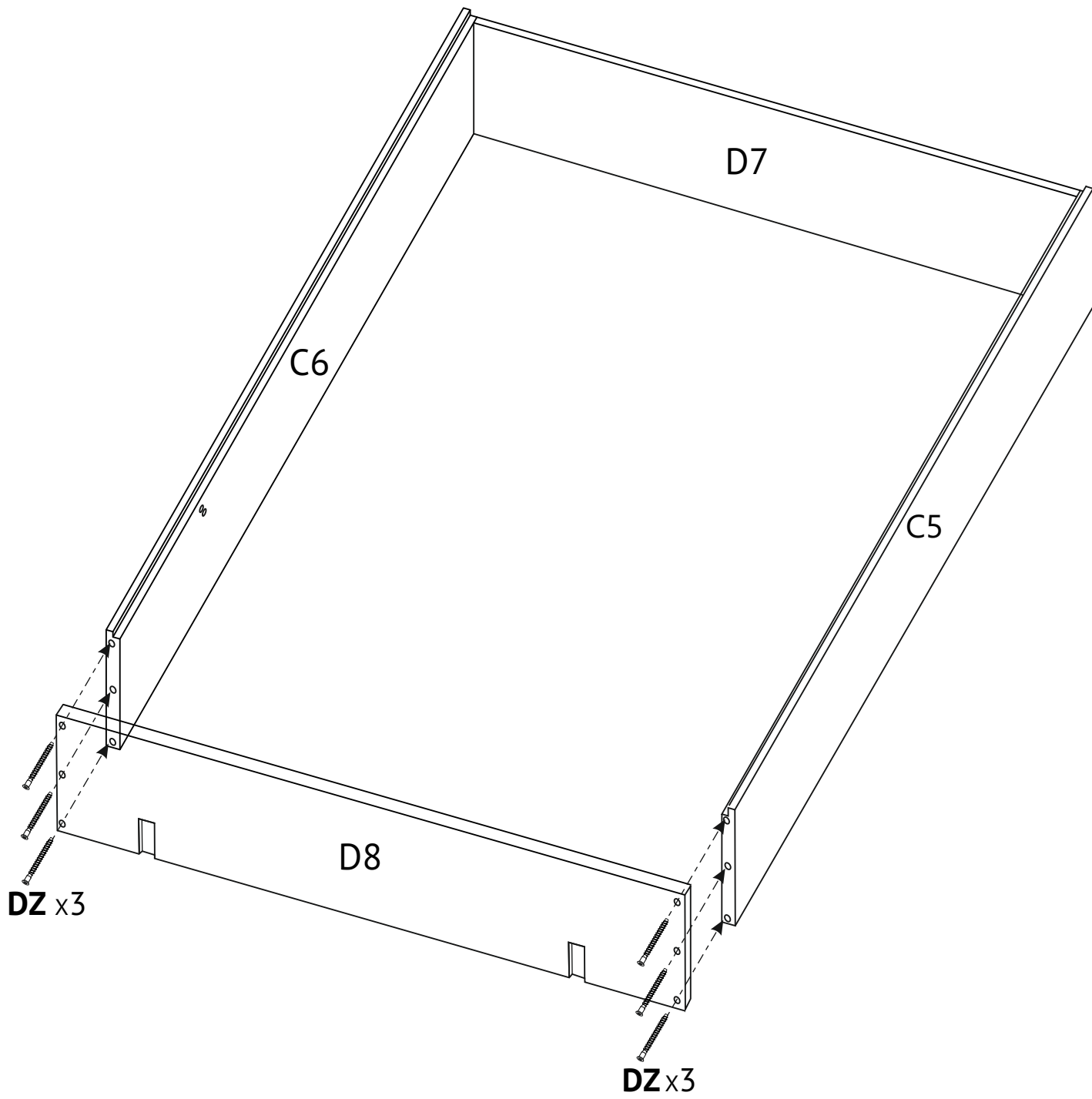



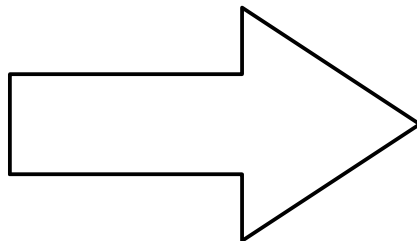
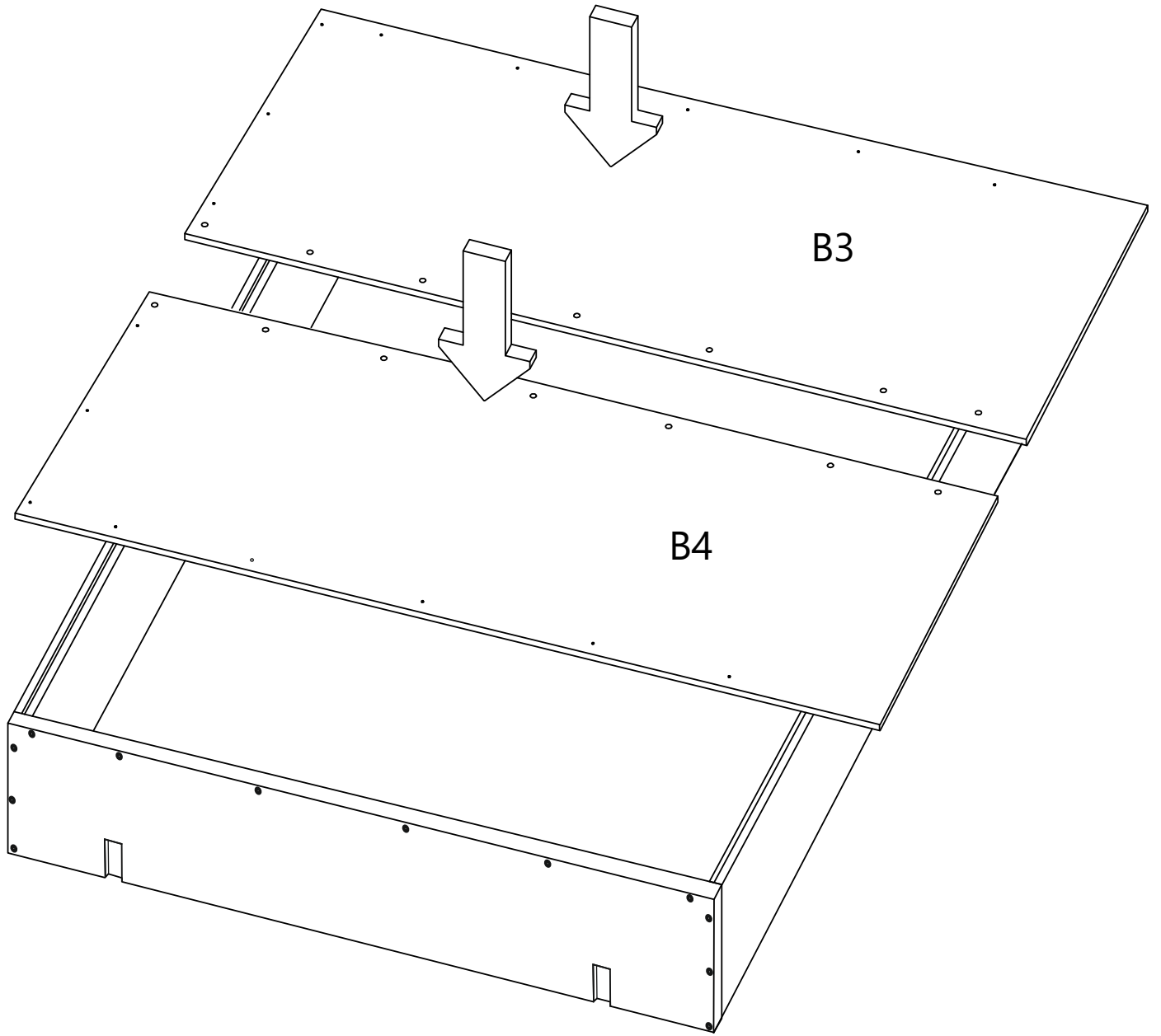

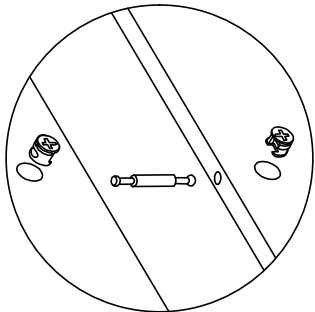
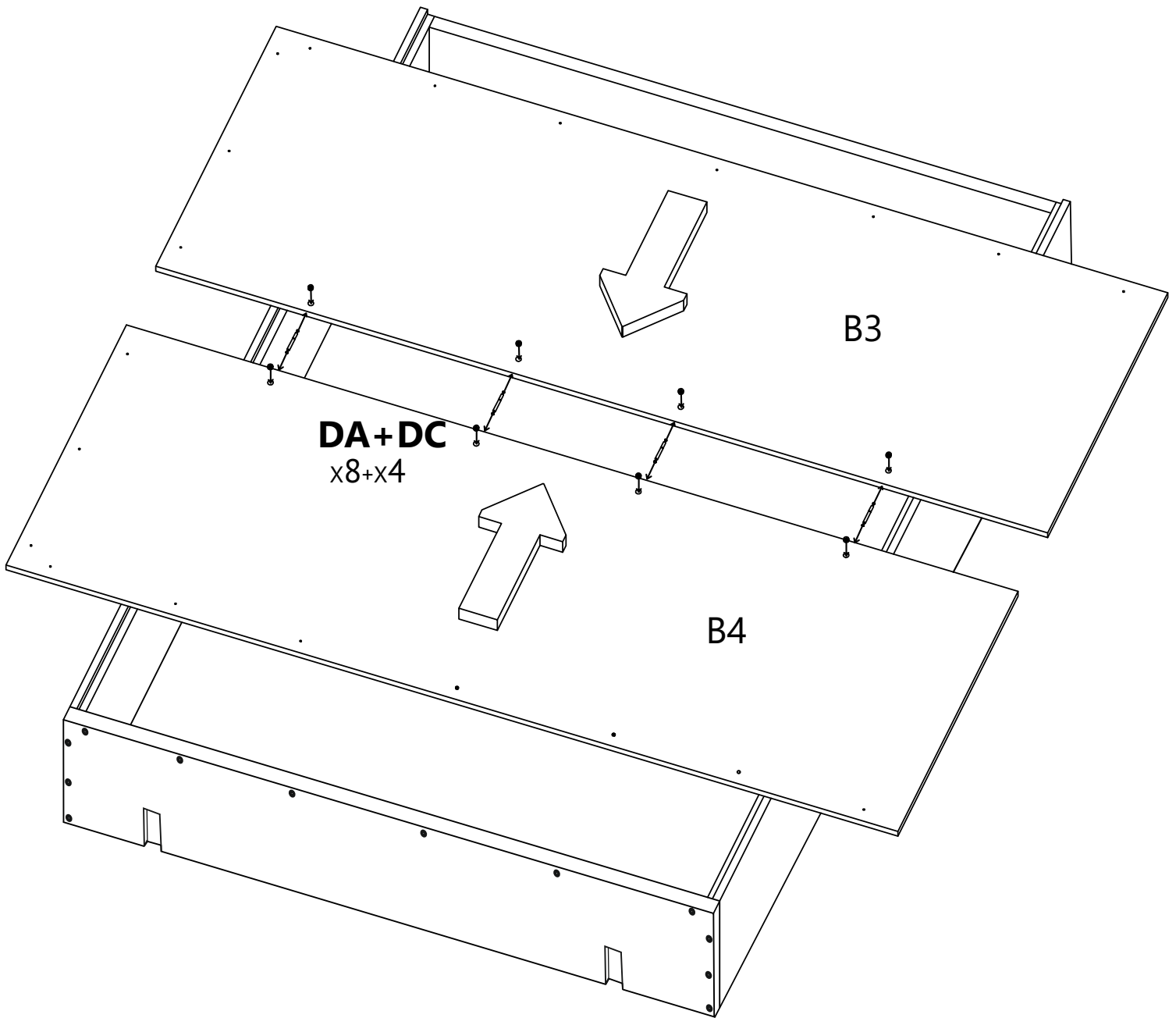

**step 1**

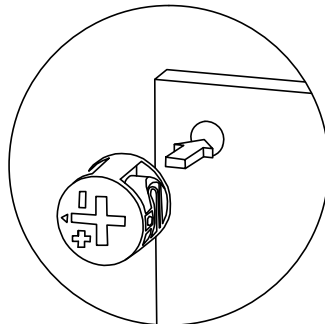
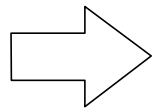

**step 2**

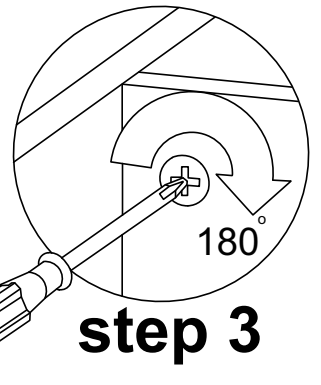
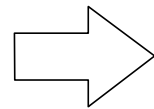

**step 3**

***We recommend you pick this up with at least 2 people, do not attempt this with 1 person as it is heavy***

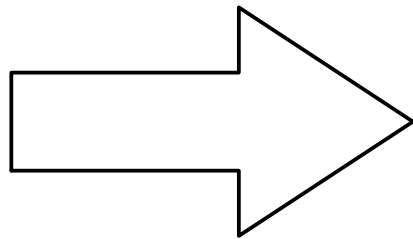
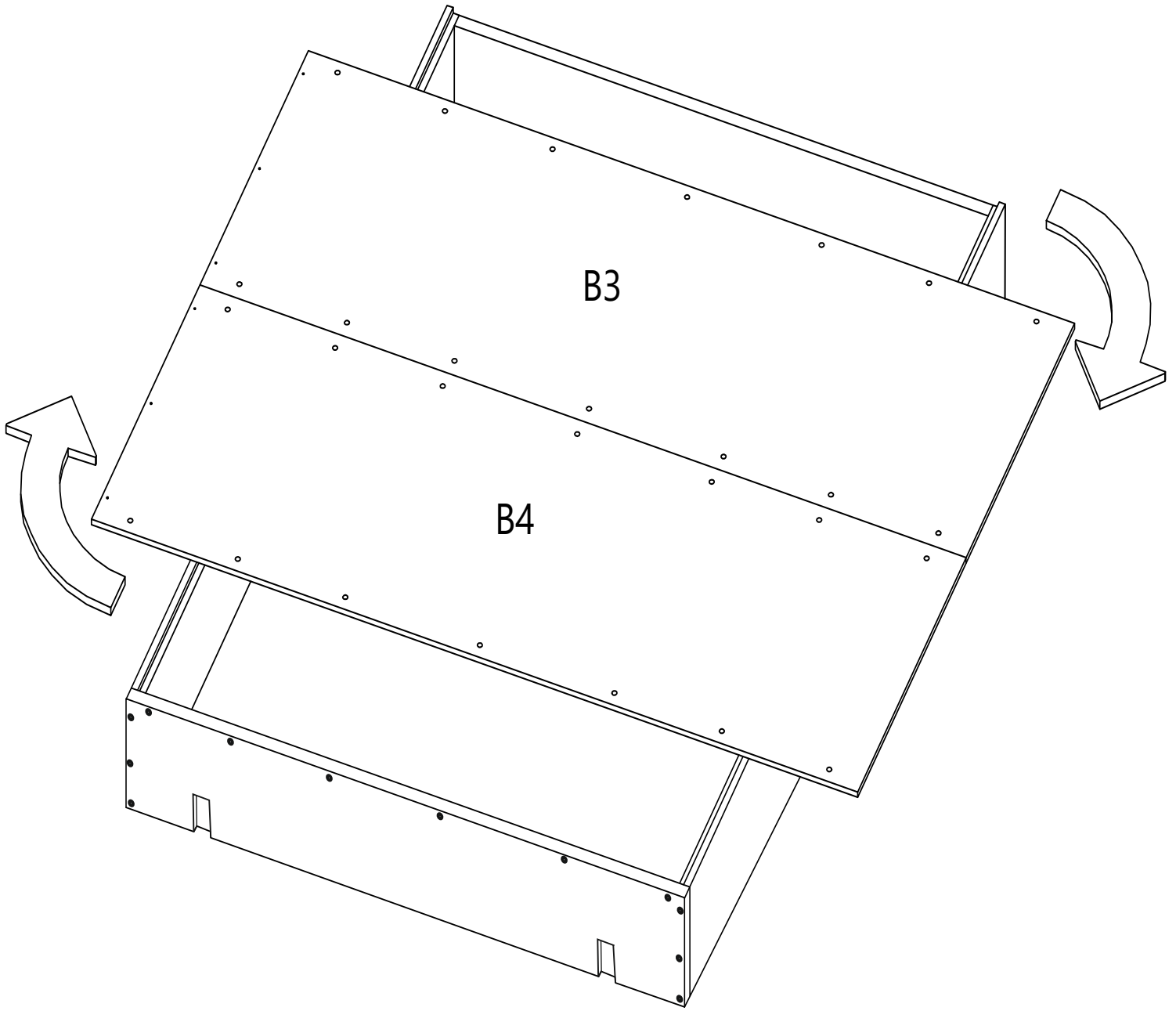

*If you have trouble installing this part, or it feels too tight, try lift the middle of the connected b3/b4 panels which will help them fit in.*

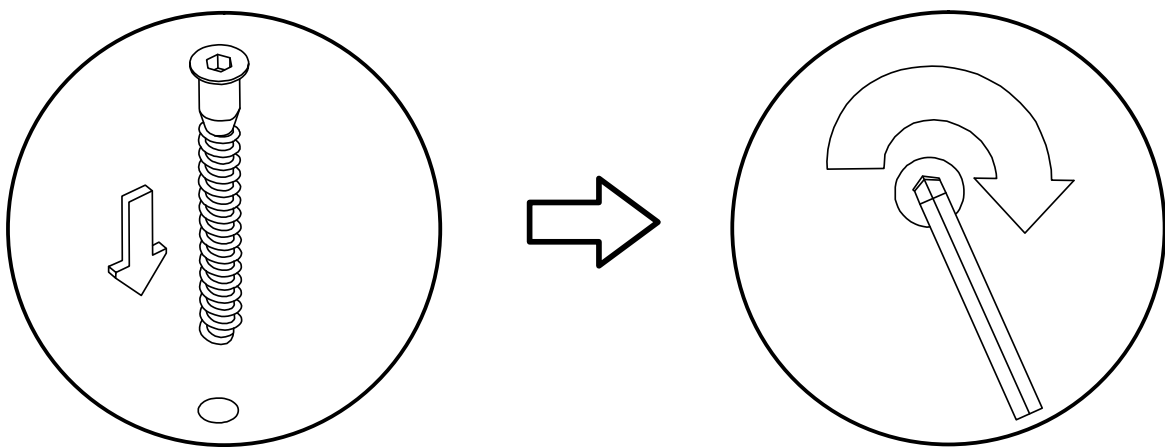
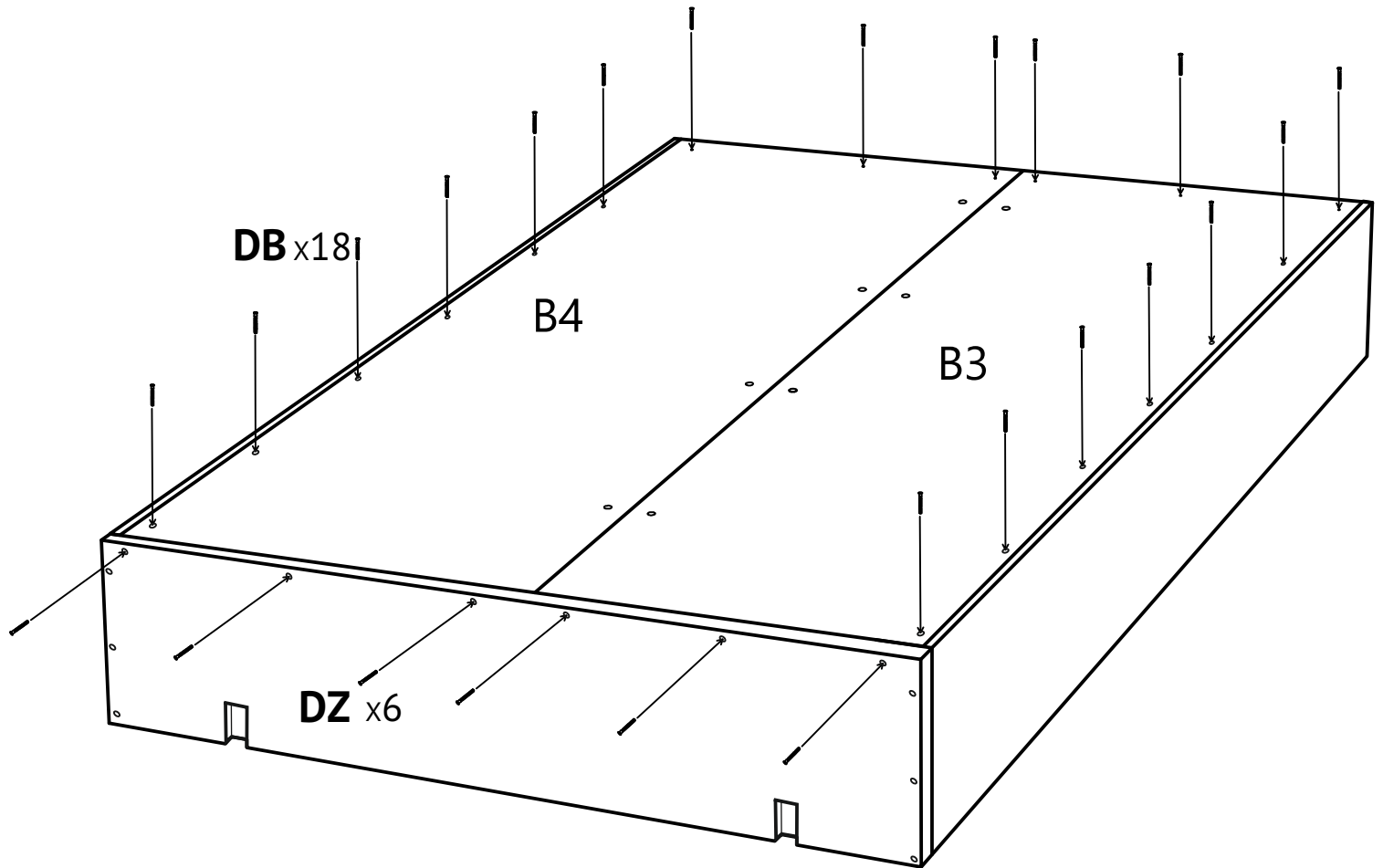

*Make sure to evenly distribute these bolts around the bed until you have none left. You only need to install 3/4ths of these bolts. If you have trouble threading a hole, skip it and move to the next one (you can try this again later if you have left overs, the more that are in, the easier it will be.)*

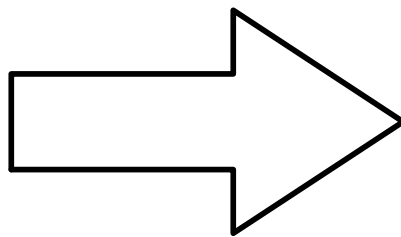
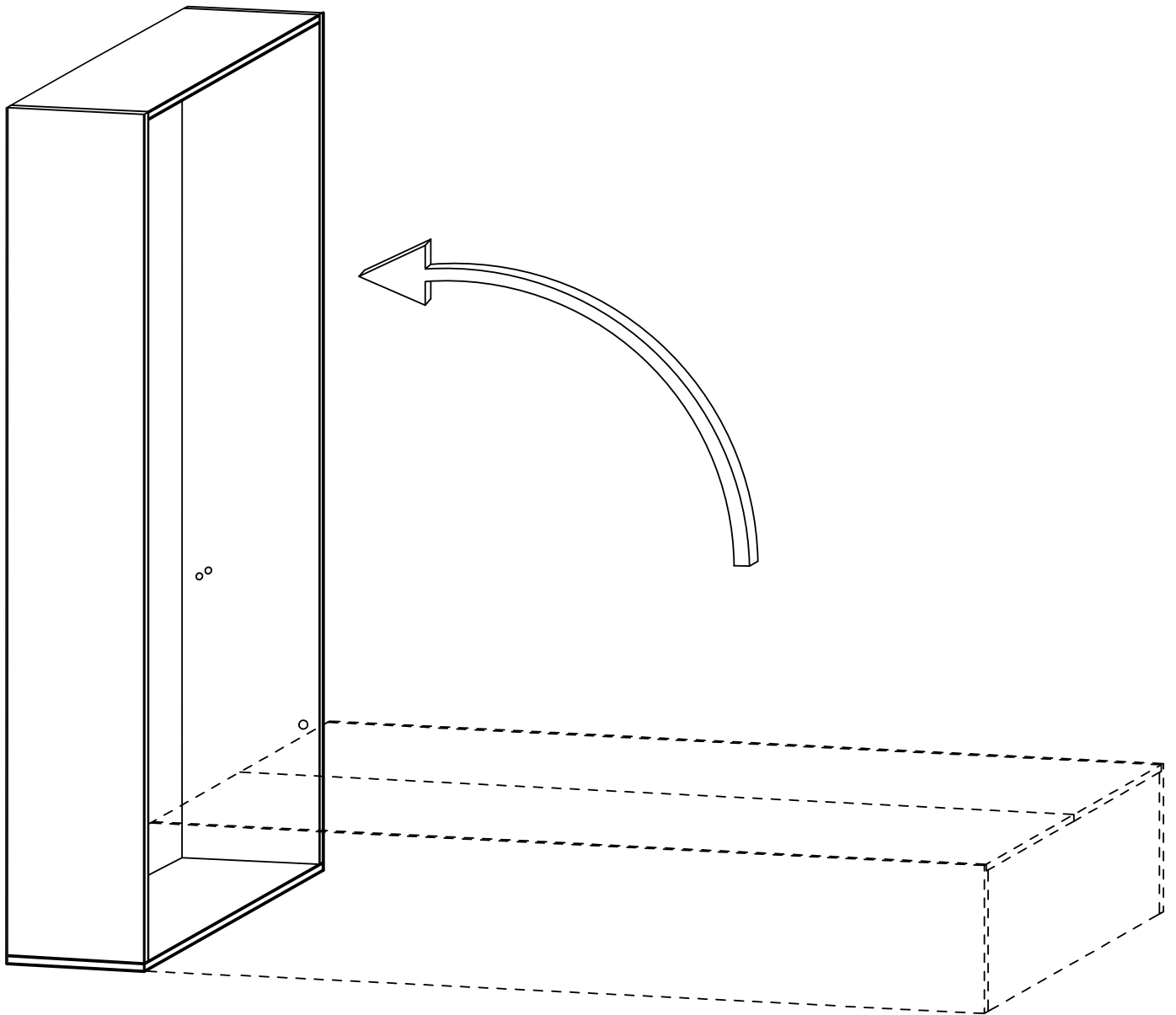

Raise your bed, you should have at least 2 people lifting for safety.

If you have cabinets, you can build them and place them now.

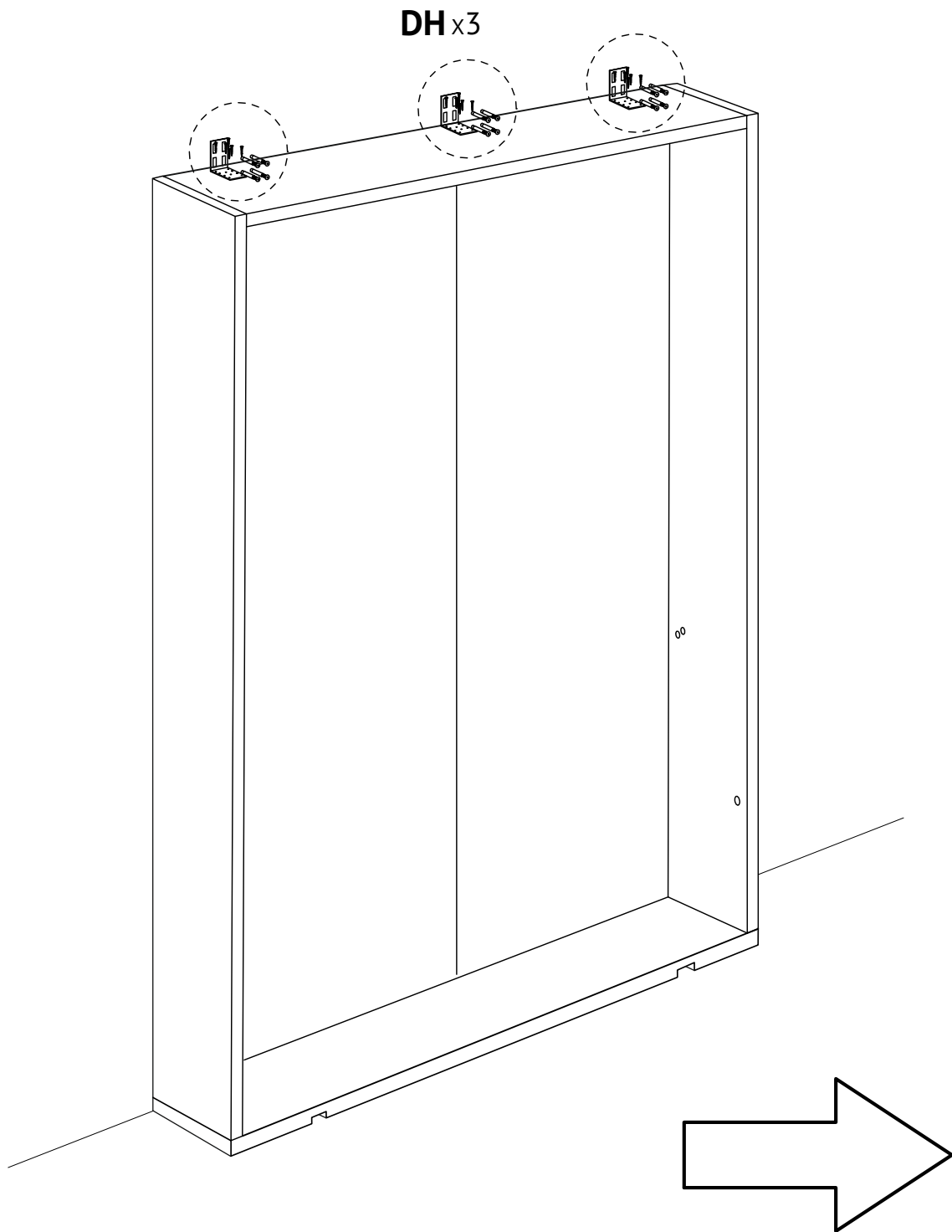

### ***Fastening the bed to the wall***

*It is important to determine the type of wall you have, you should purchase anchors/fasteners appropriate for your wall.*

*We do not provide anchors because there are a variety of wall types from concrete, brick or drywall (with wood or steel studs) require different anchor types. You should buy heavy duty anchors that have a high weight capacity (100+ lbs per anchor) and are appropriate for your wall type. Please consult your local hardware store or handyman.*

*"We provide 3 brackets which allow for 4 anchors each. You can place them on left and right side of the bed. They are flexible so you can line them up with your studs (if you have drywall) where you place them. It is best to place them wider apart and evenly spaced. We strongly suggest adding a few more simple brackets with extra anchors in the middle for some added security"*

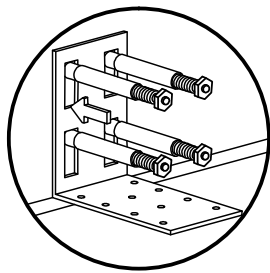
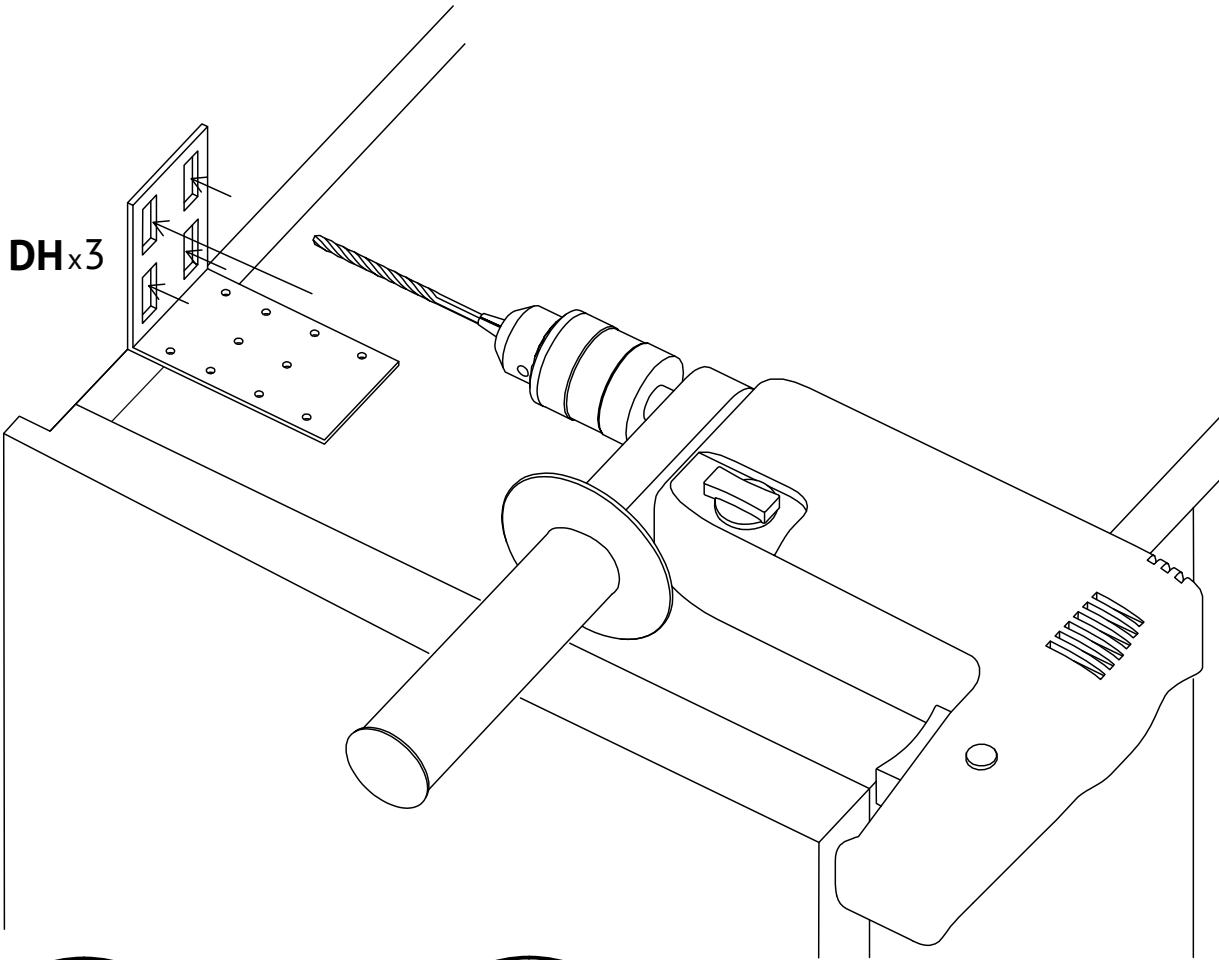
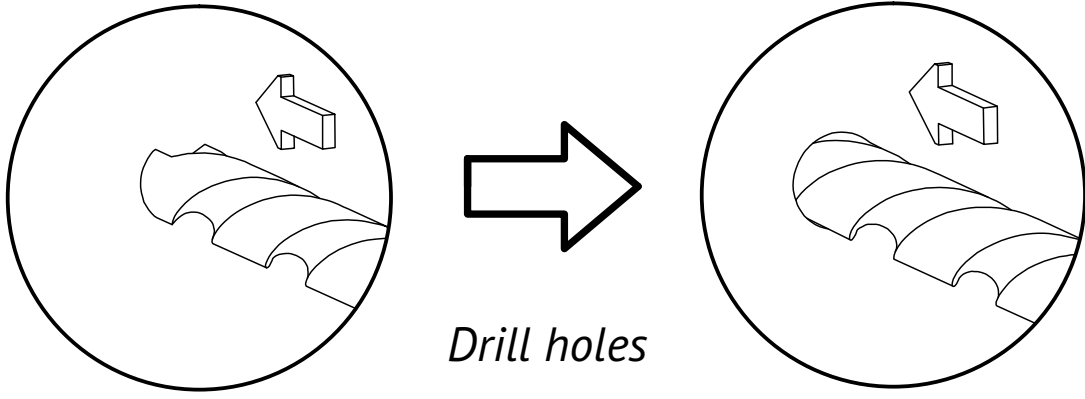

step 1

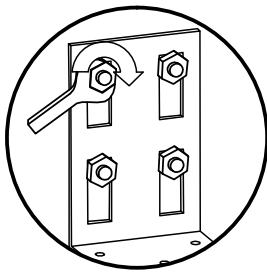
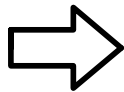

step 2

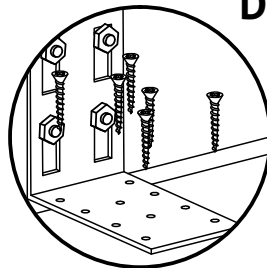
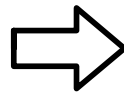

step 3

DDx18

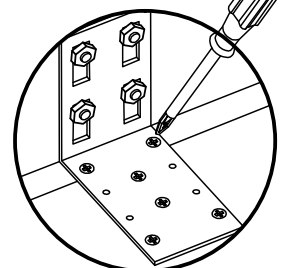
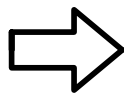

step 4

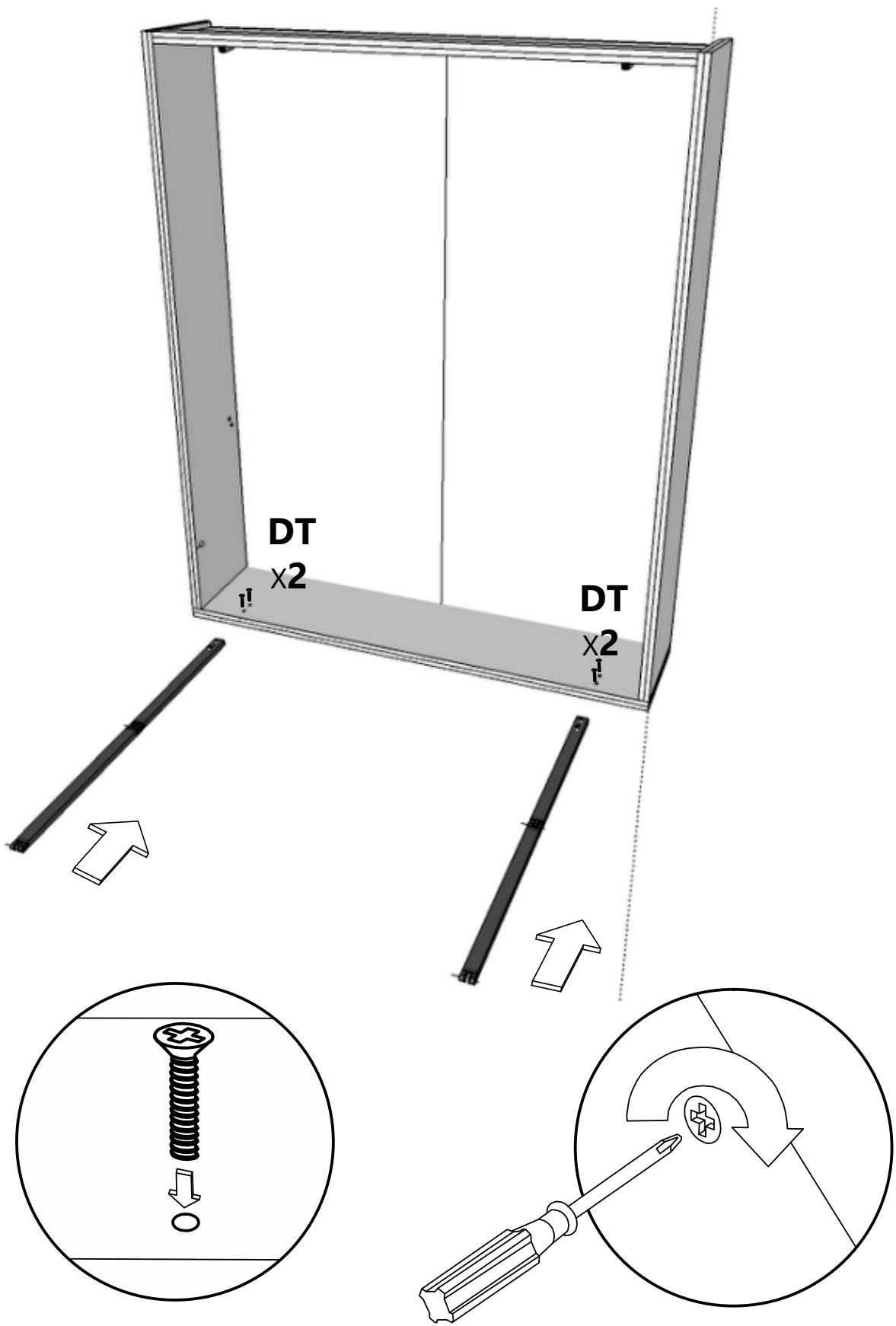



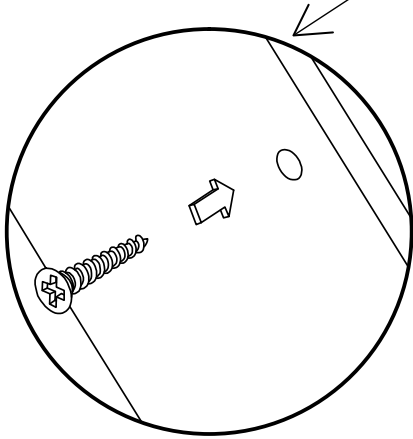
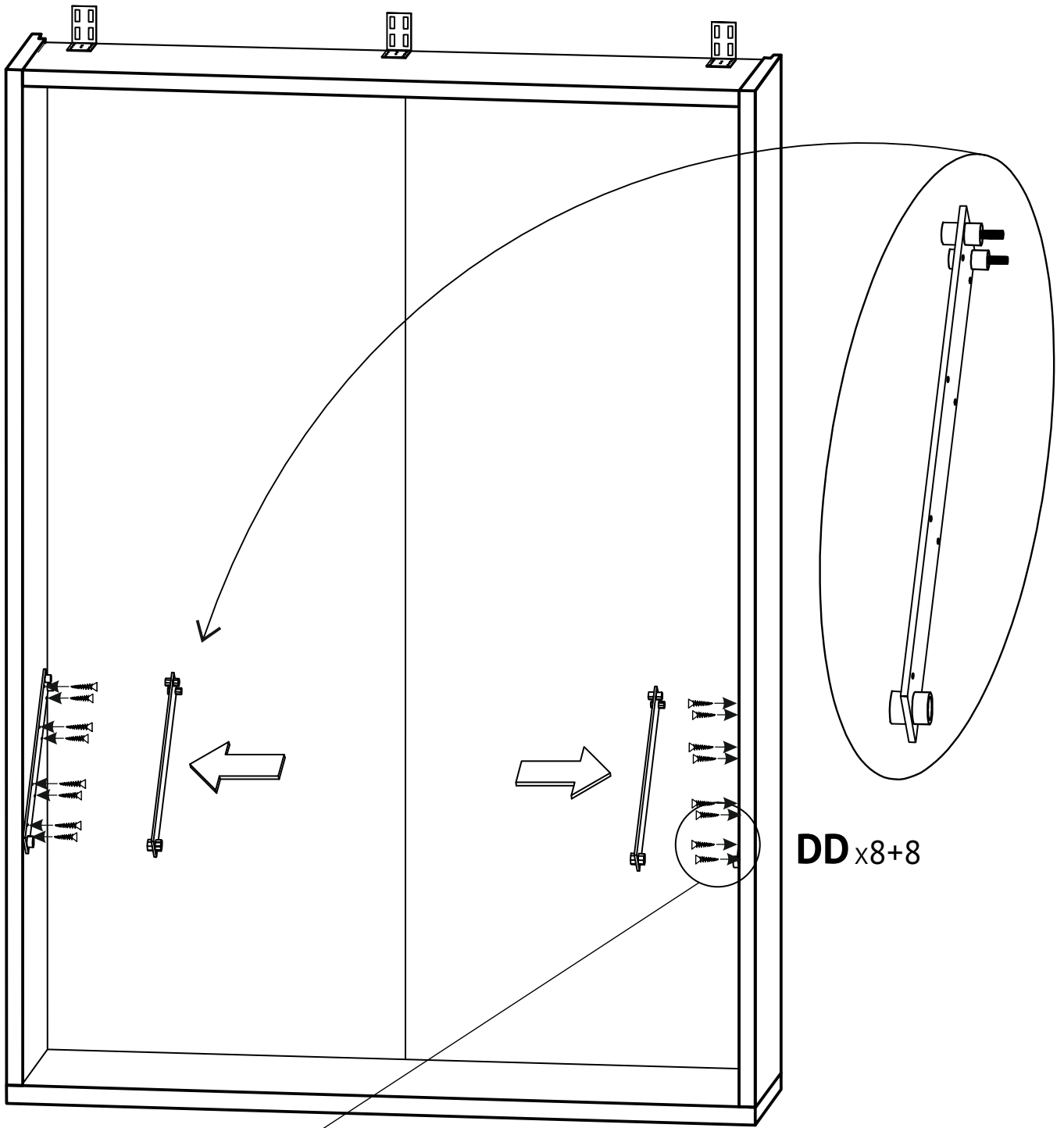

step 1

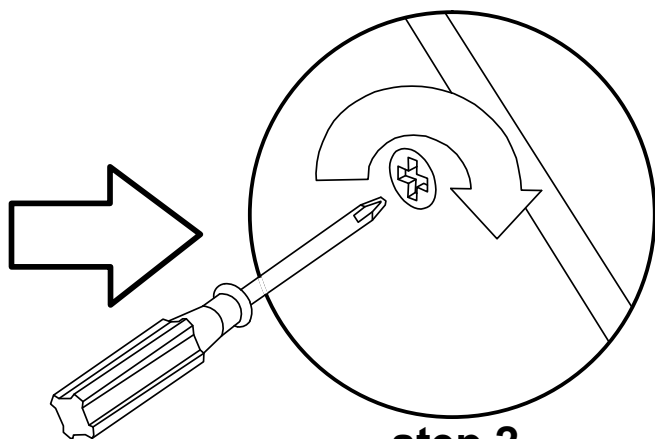

step 2

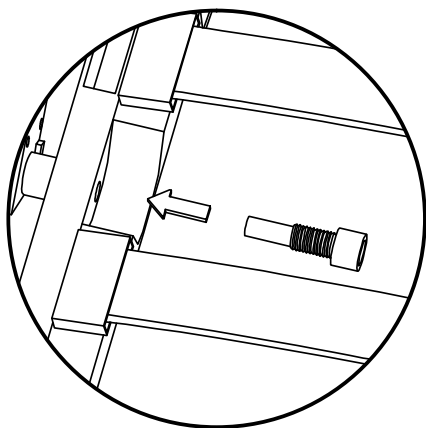
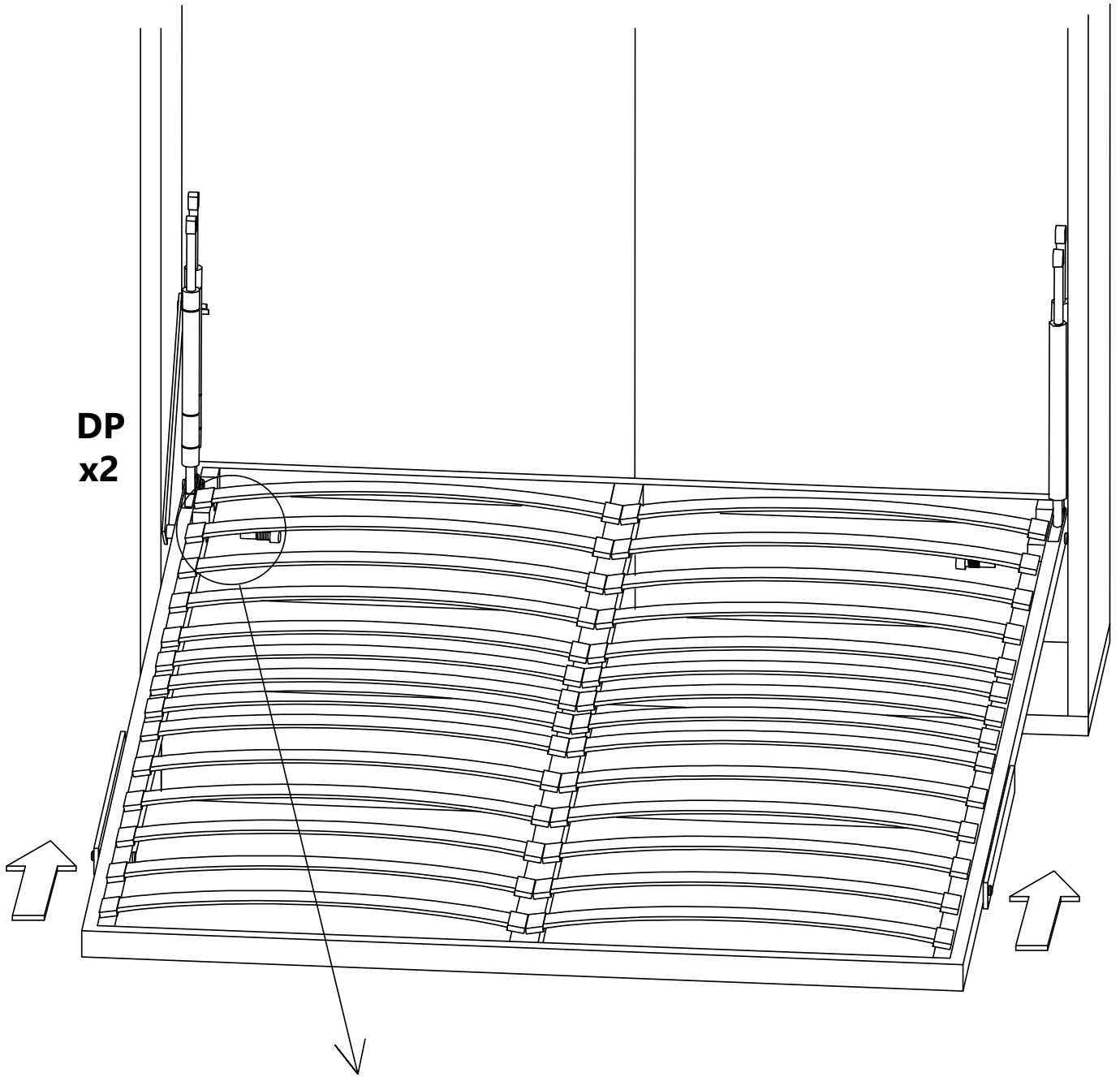

**step 1**

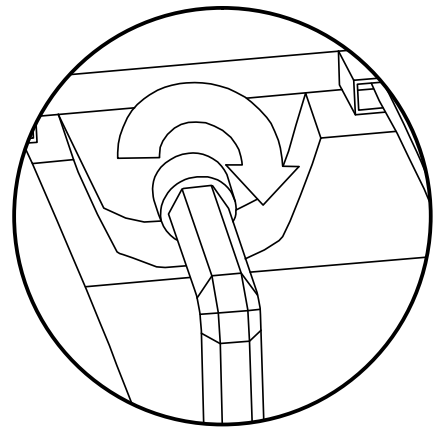
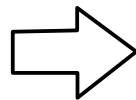

**step 2**

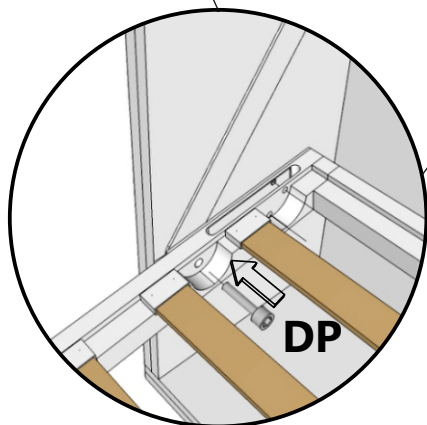
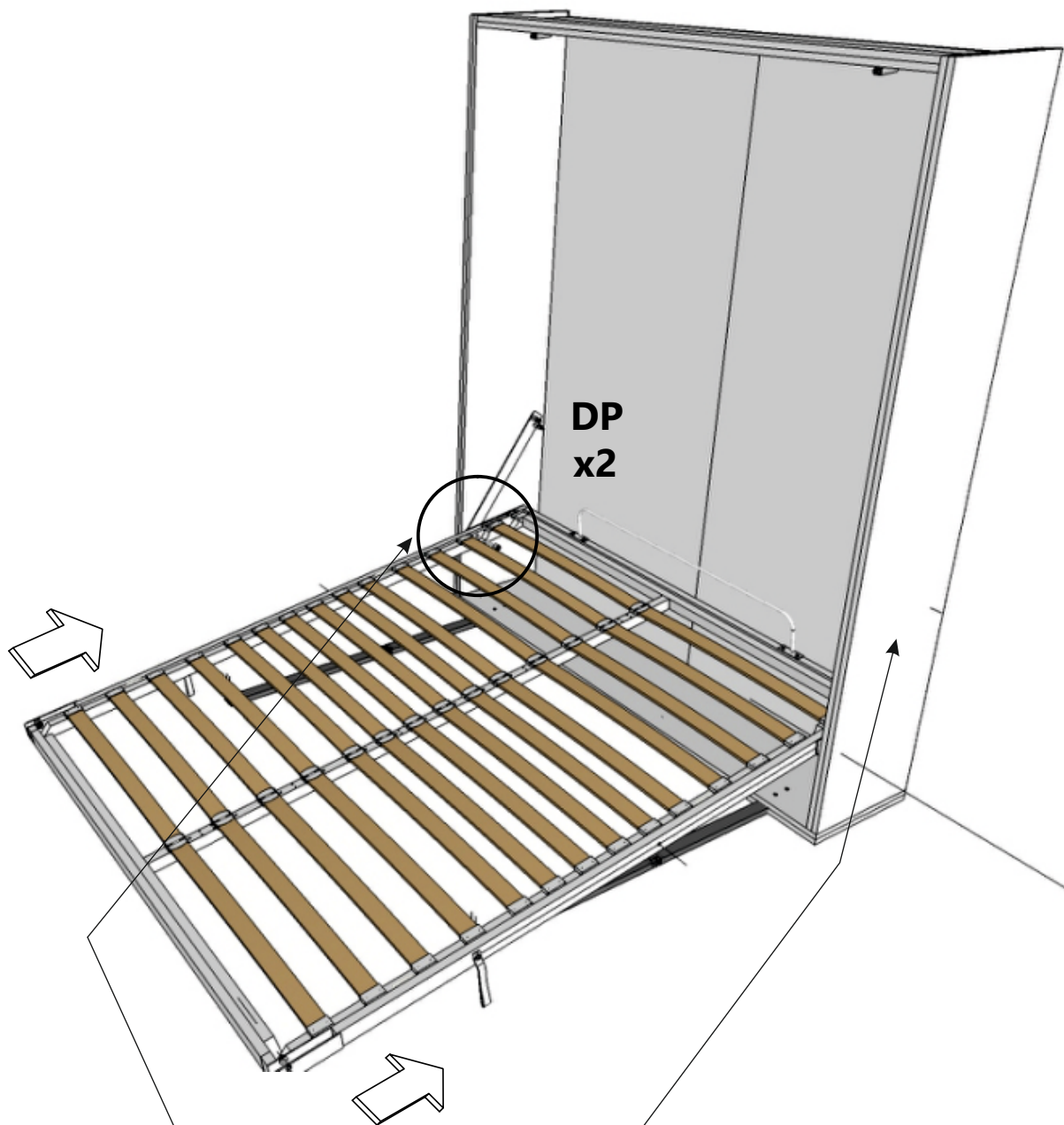

Step 1

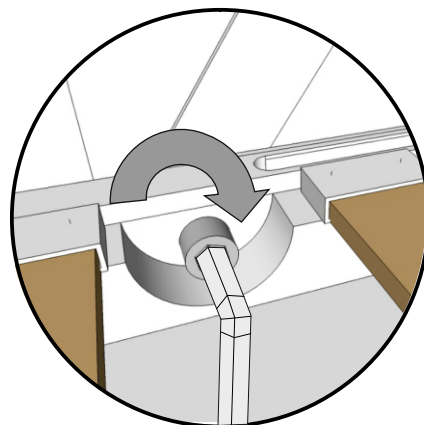

Step 2

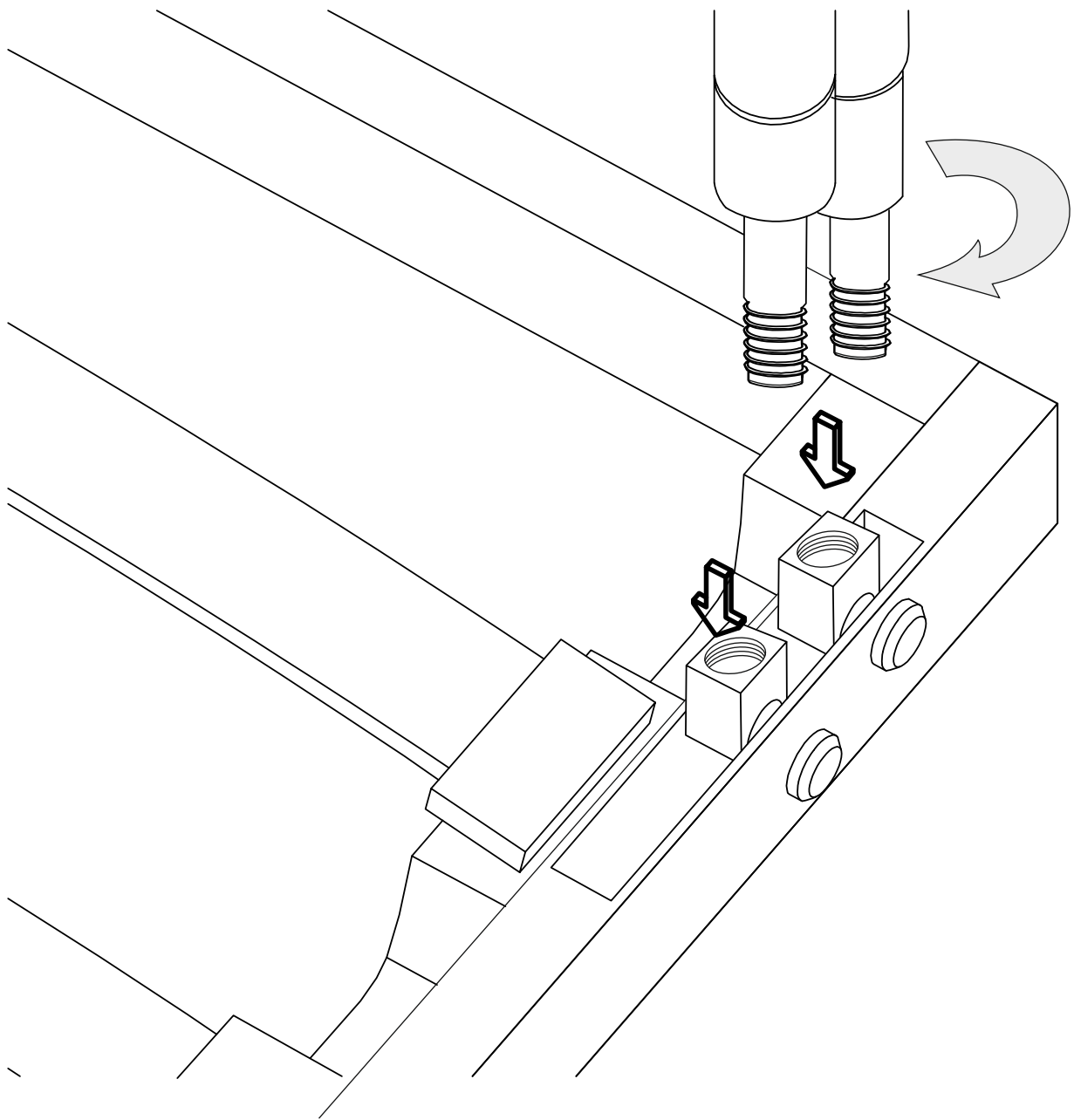

with the one side of the piston end cap already in the frame, so the piston can be rotated to connect

## **Piston install**

*The pistons do not compress by hand. They need to be placed fully extended into the bed after the frame is set in the correct position.*

*When you install this Gas Piston make sure you push the bed frame inwards, beyond flush, so that it is inset at least 4 inches. This creates inwards pressure. Don't worry, later you will add on a stopper to the top of the bed and the face panel will be flush.*

*Once the bed is set at the right position (4 inches pushed inwards at the top) you can attach the pistons to the sides. The top caps can rotate in either direction to elongate or contract slightly so that you can make them fit at the correct inset position.*

*We have an online video guide for this sent by email you can watch.*

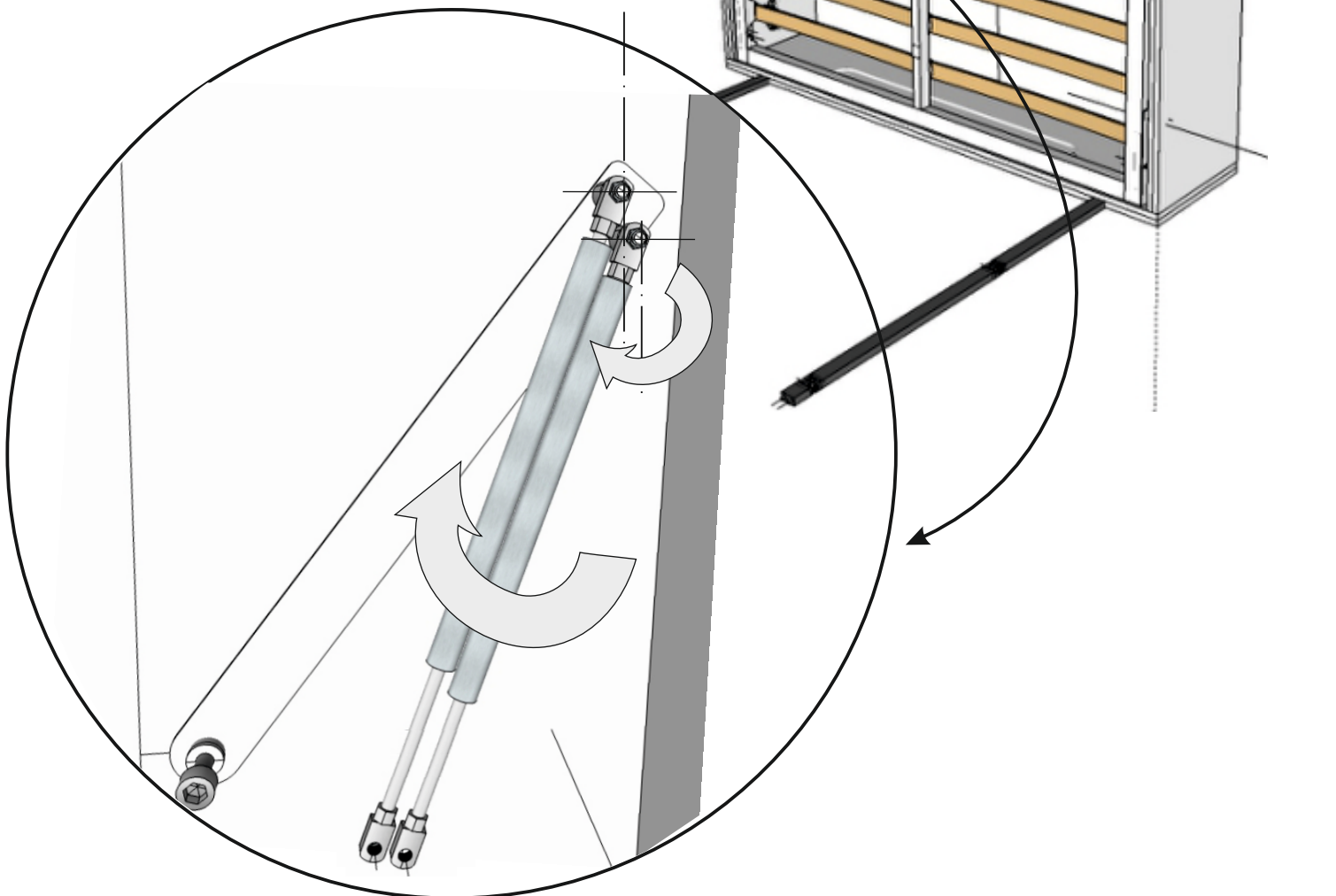

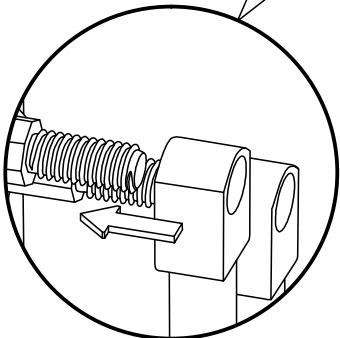
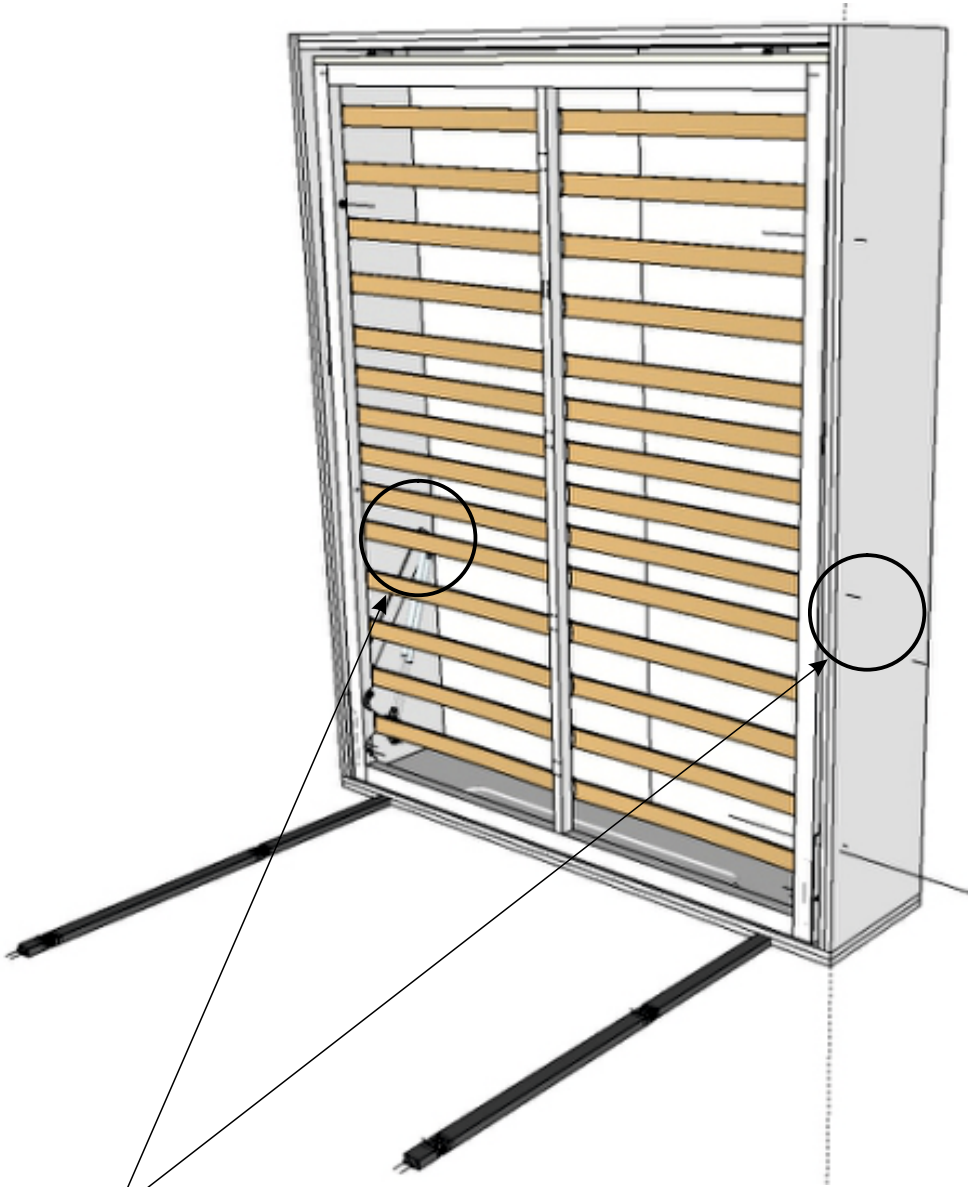
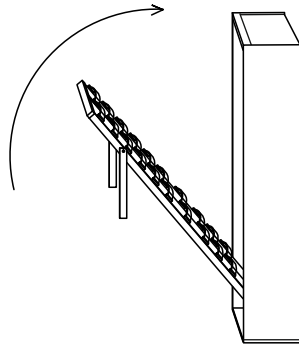

**step 1**

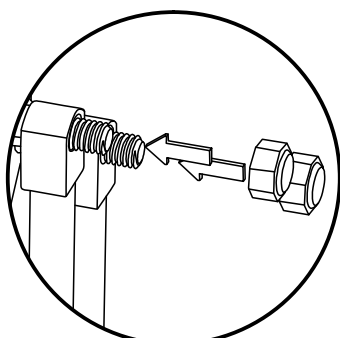
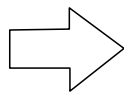

**step 2**

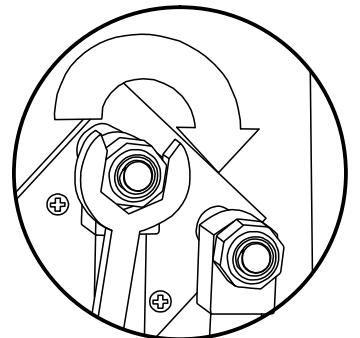
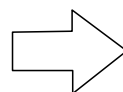

**step 3**

There is a Styrofoam part like this in the box.

If you lost it or don't have it, use something soft to insert at the top to keep it slightly open. A cushion works well.

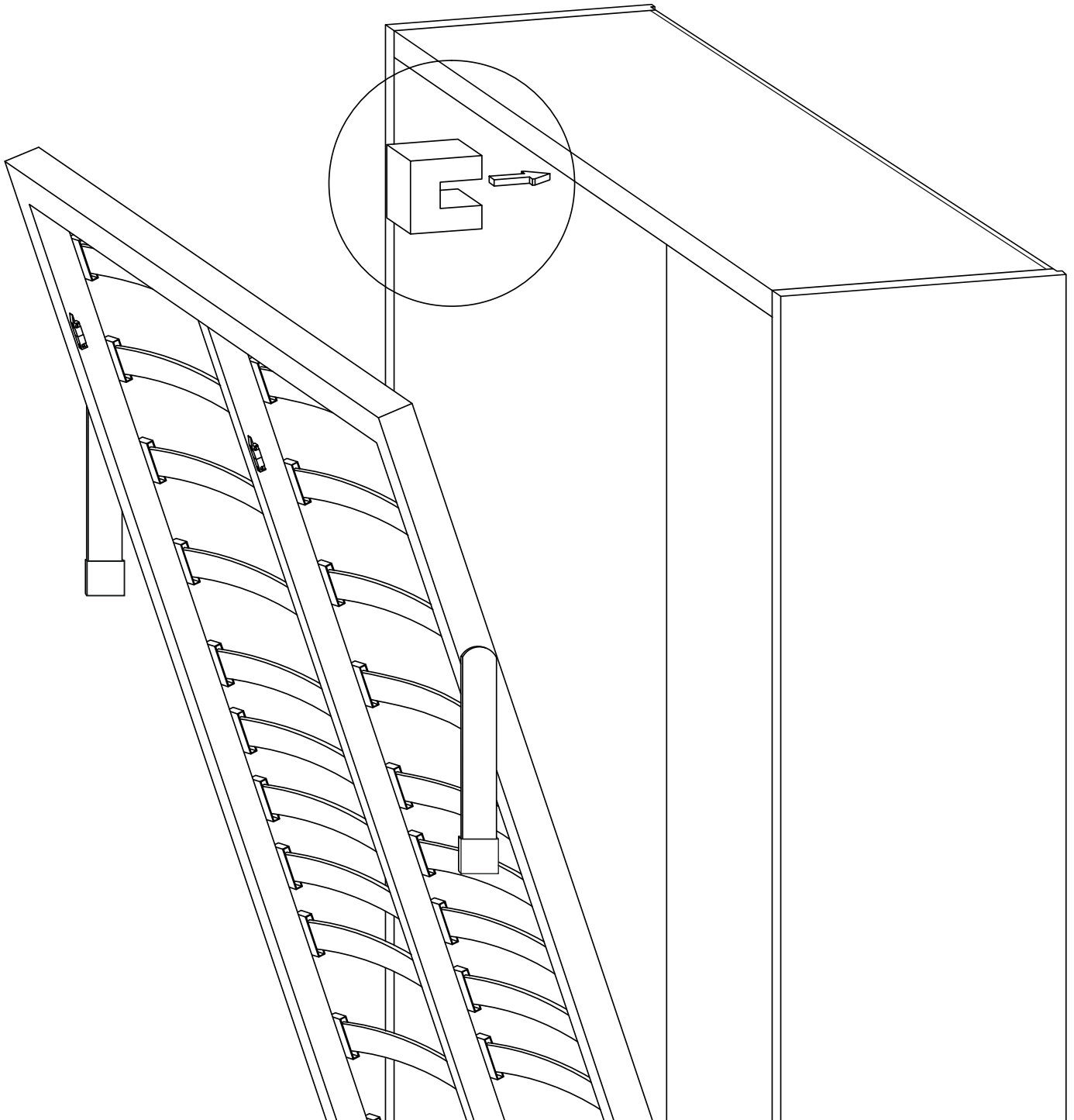

## Face Panel Clips

Please measure the clips to make sure they are in the right position before drilling them in. This might require some slight adjustment. You can reposition these a few times if needed if you have trouble putting on the face panels.

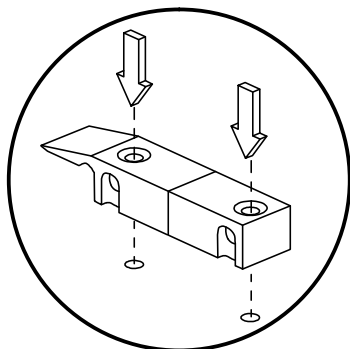
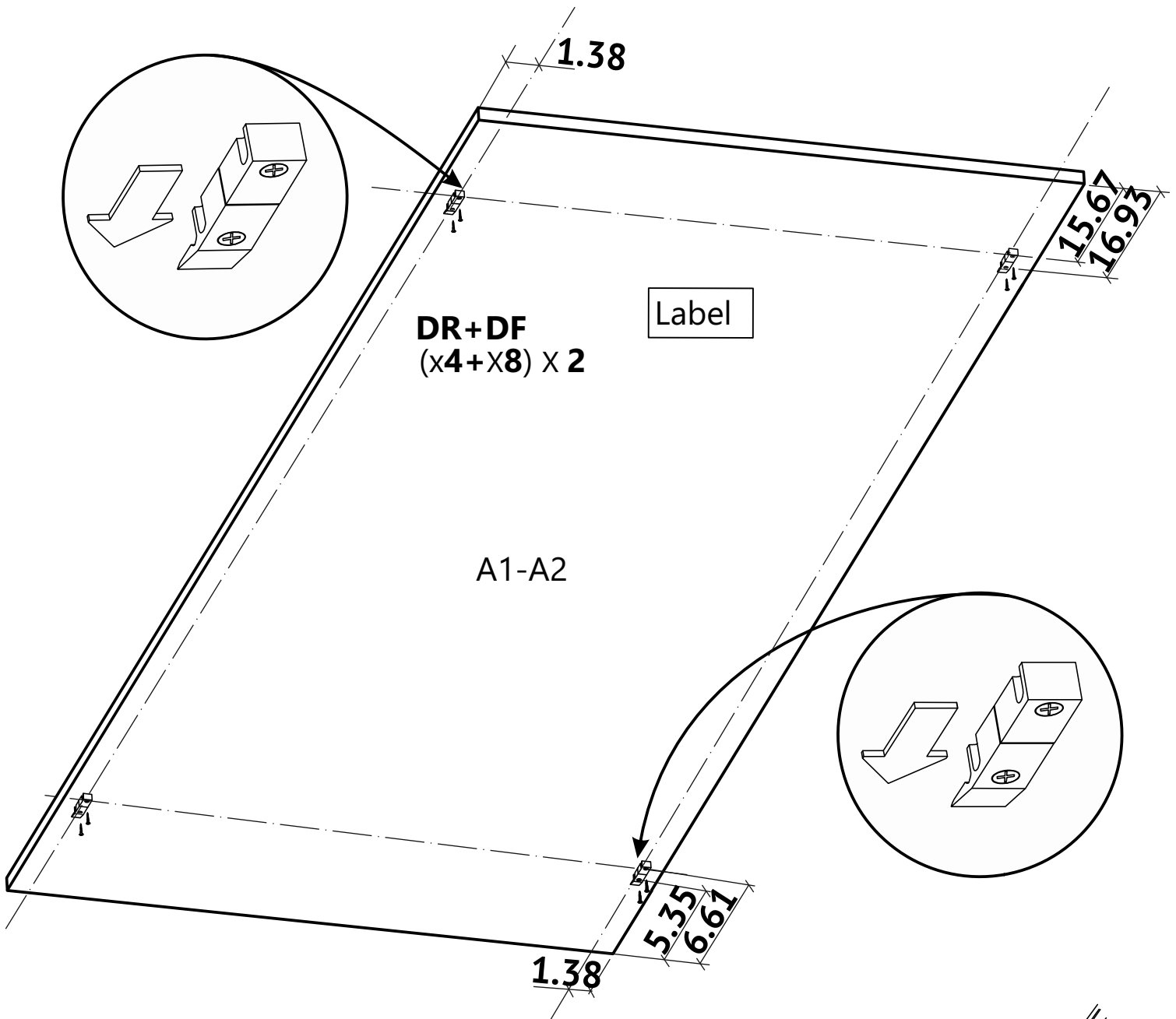

step 1

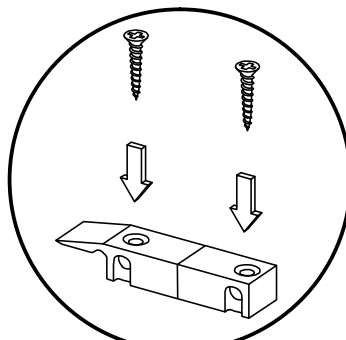

step 2

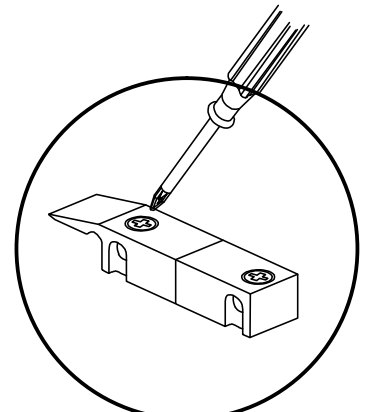

step 3



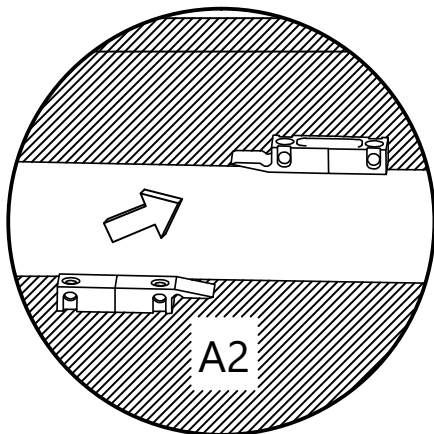
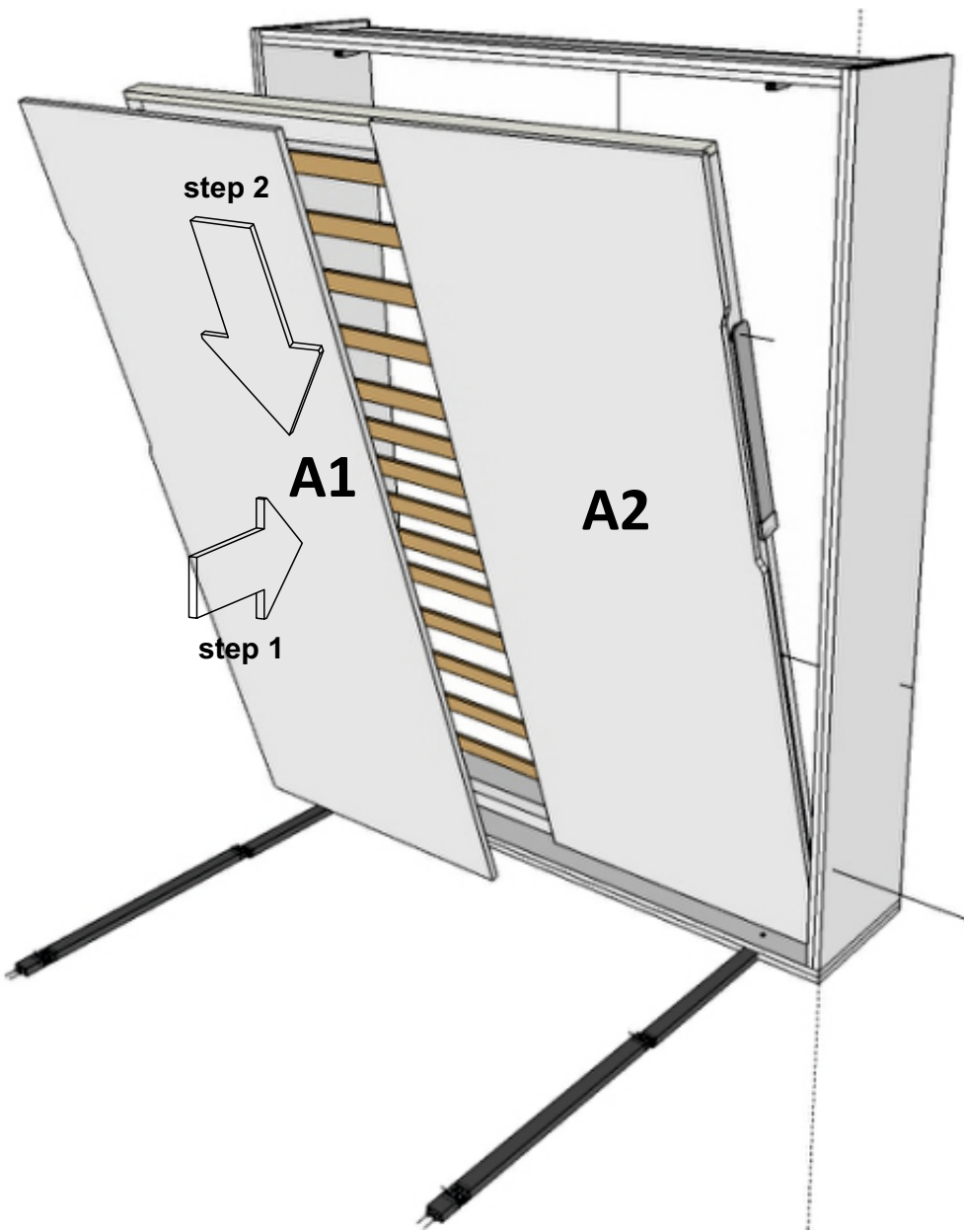

Step 1

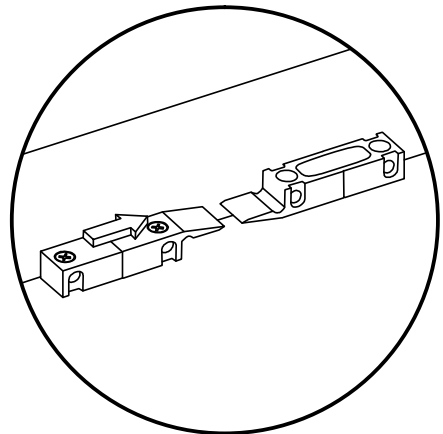

Step 2

We suggest installing the face panel with 2 people. 1 Face panel at a time.

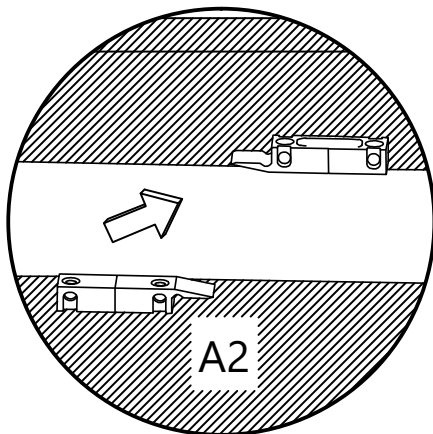
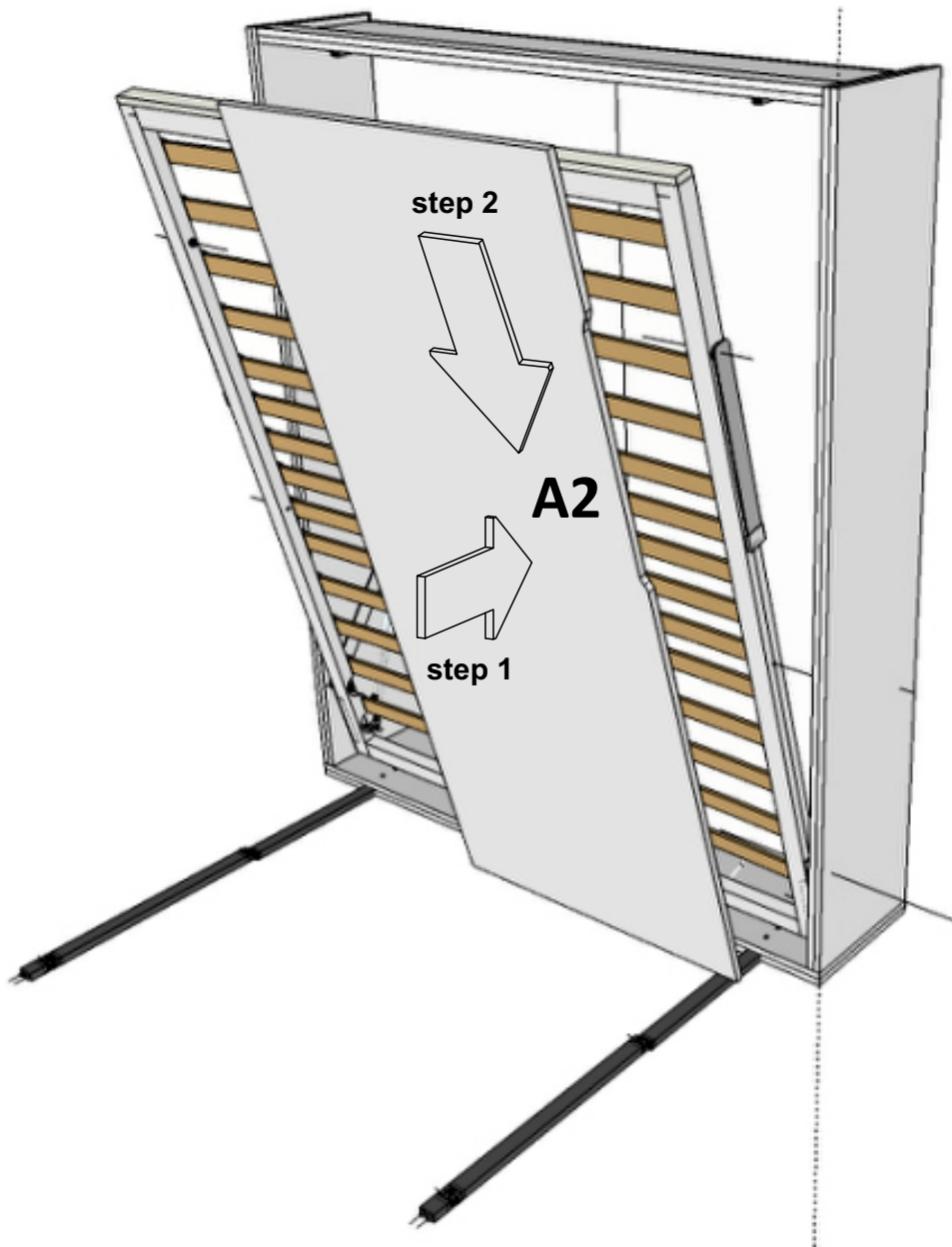

Step 1

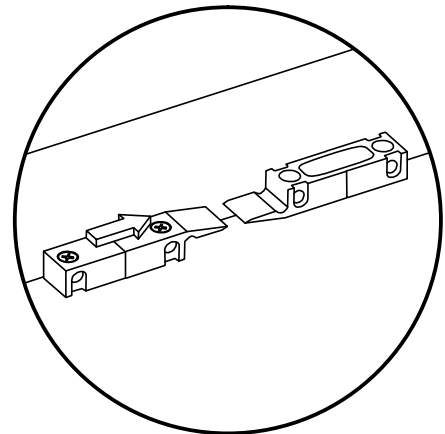

Step 2

*For this part you need 2 people.*

*After the pistons are installed it will be hard to lower the bed. This is NORMAL!*

*The system requires weight like a mattress to be balanced. So this will take some pressure to lower the bed. Have 1 person hold it down lower, while the other can do the next step.*

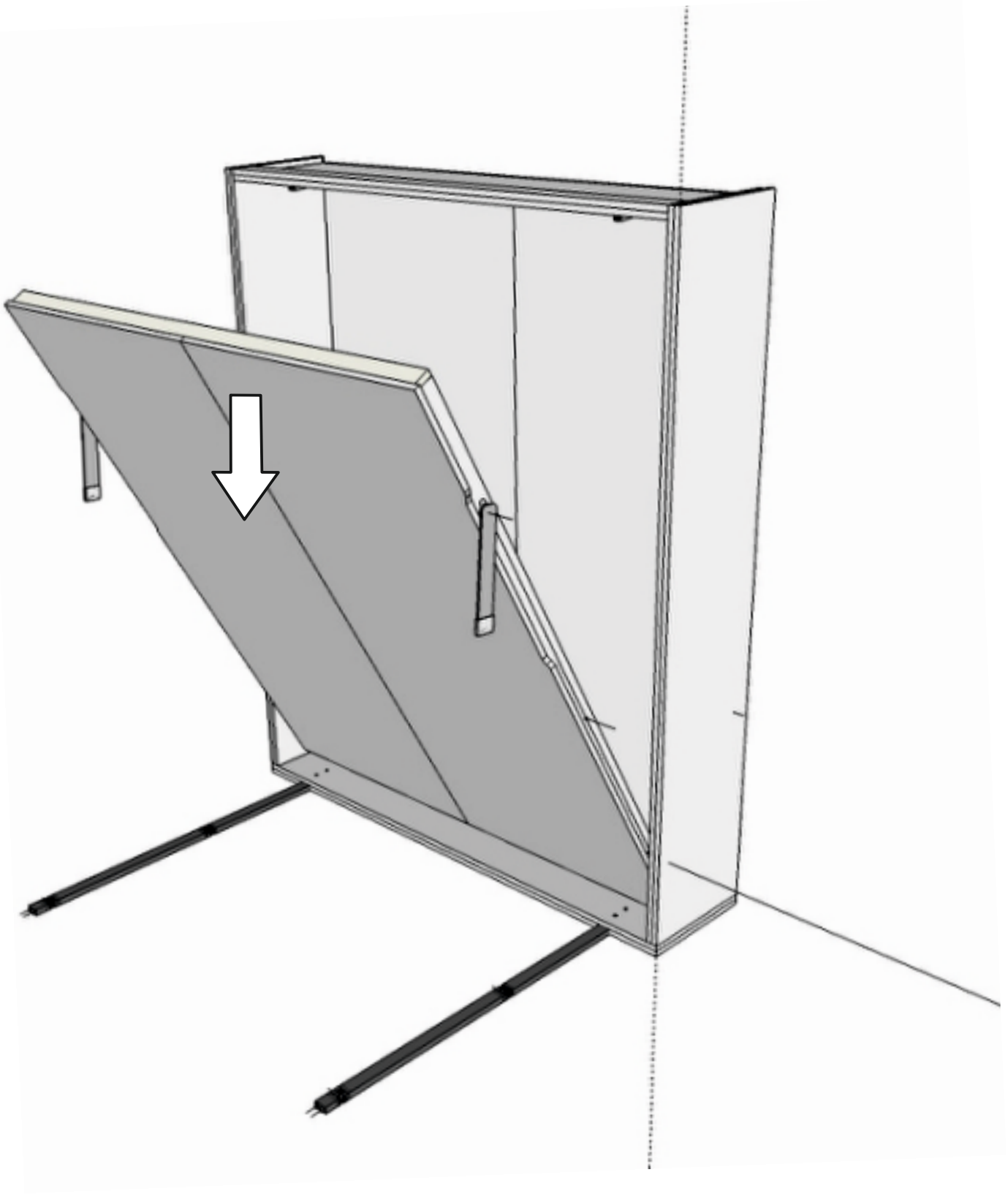

*Before drilling all the screws into the panels, we suggest putting in only a few support screws to perform some tests before putting in the remaining screws. 6 screws per panel evenly distributed is good for this test.*

*You will only use 2/3rds of the holes on the final install so please do not think you are short screws if you don't have enough for all the holes.*

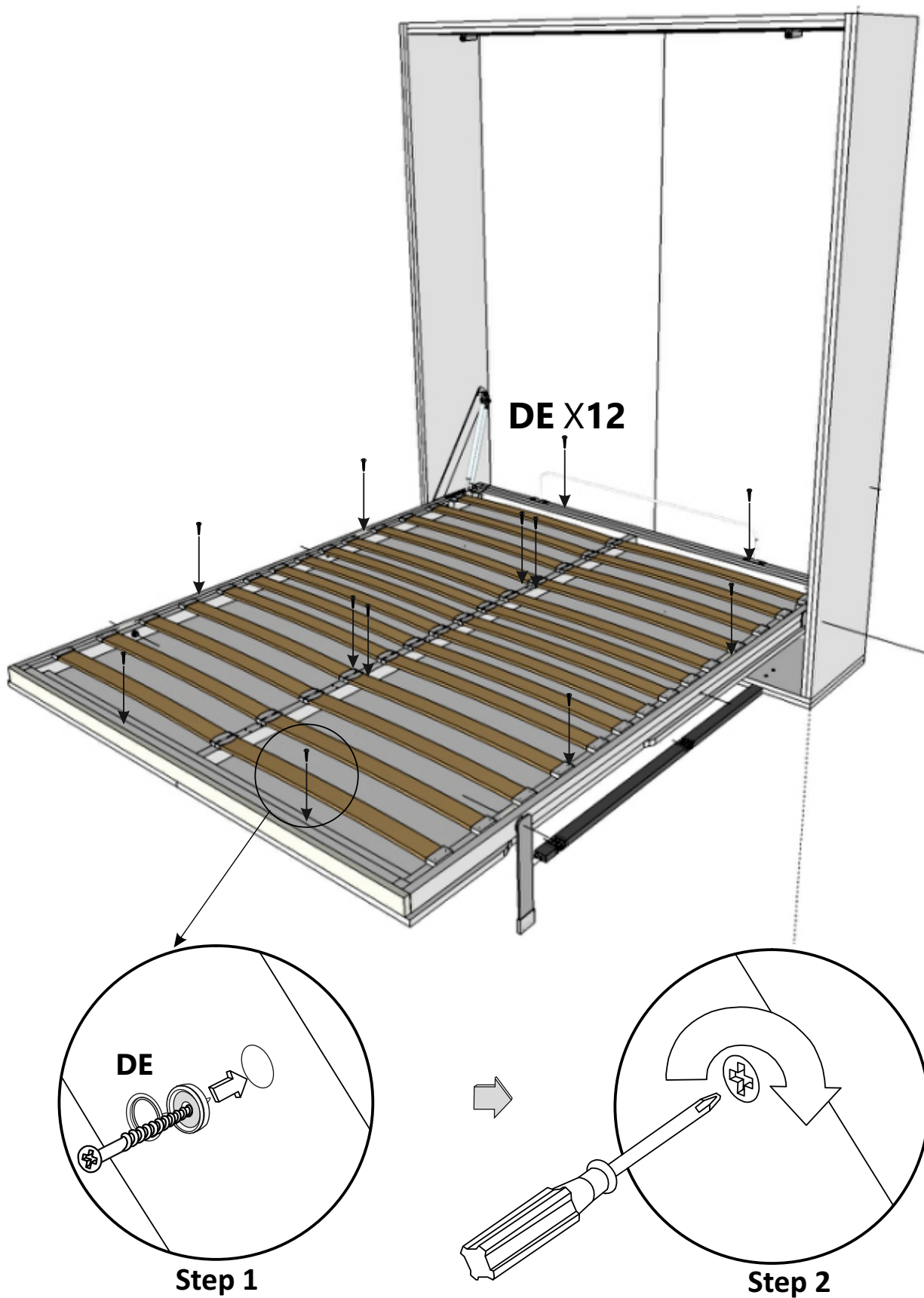

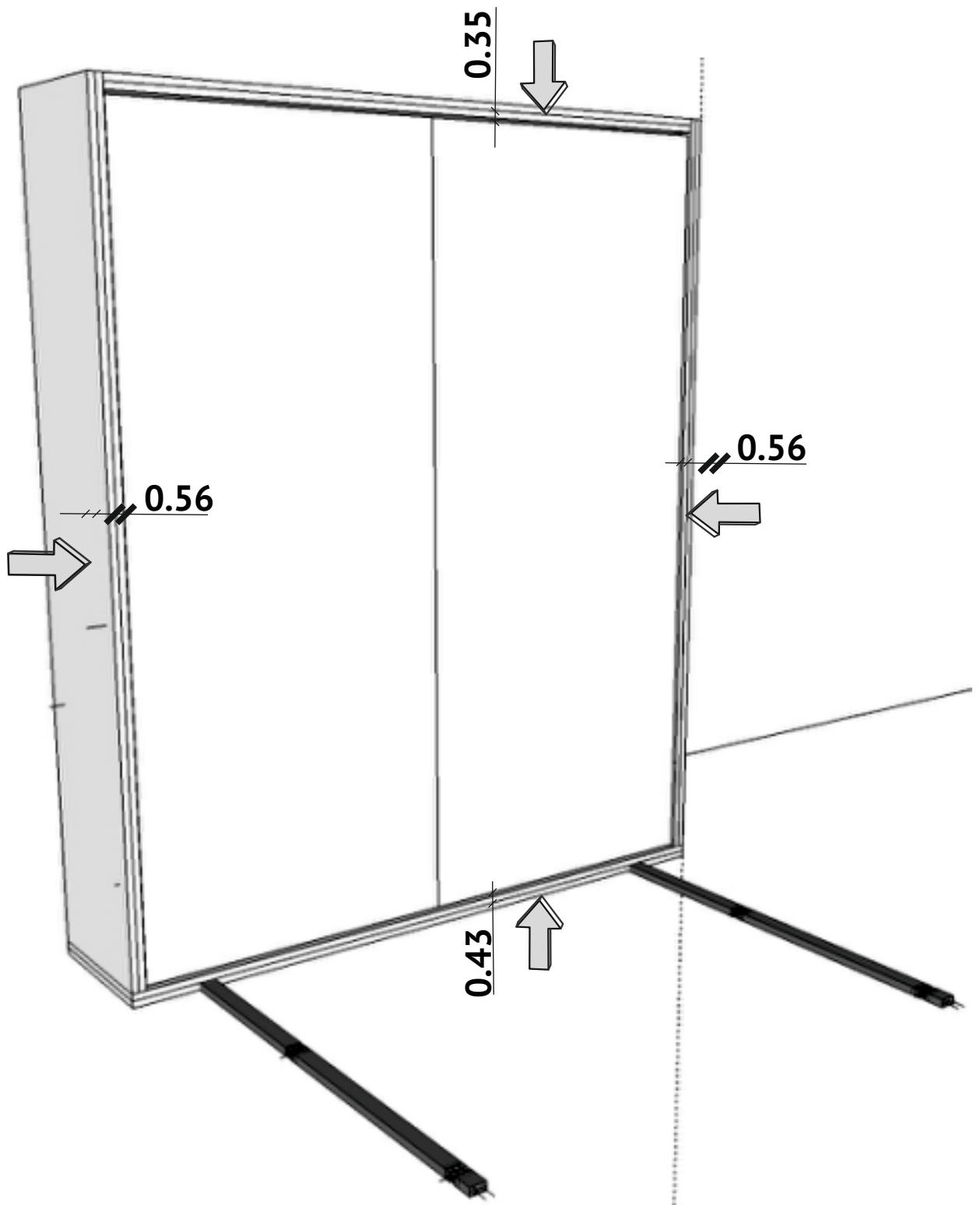

*Test 1: Raise the bed up again and see how it looks and that you are happy with how it is aligned. If it is not correct the clips might need to be adjusted slightly. This can be a subjective process for the alignment.*

*Test 2: Make sure the bed frame is not hanging forward.*

*Raise the bed up with the mattress inside. If it is still slightly inset or flush you can proceed to the next test.*

*If it is hanging forward this is not correct, and the frame needs to be inset further. Please remove the face panels and restart the gas strut/piston install process with the frame set further inwards.*

*If it is inset properly, with a 2nd person, put your mattress on the bed. Raise the bed up. If the bed is hanging forward, you need to remove the face panel and restart the gas piston install process with the frame set further inwards.*

*Test 3: Lower the bed. Does it stay down with the mattress on it? If the answer is yes, then you can install the rest of the screws after the desk has also been installed and tested for a balanced weighting. You will only use 2/3rds of the holes on the final install so please do not think you are short screws if you don't have enough for all the holes"*

*If the answer is no and it hovers slightly this should be okay as when you add on your desk as well as the bedding it will stay down. You can test this by adding some bedding or a even by putting the desk on top of the mattress while the unit is down to check the balance. When you add the desk and the metal work, this will add extra weight. If it is staying up quite high in the air you might require weaker gas pistons if your mattress is too light.*

*You also might have set the bed too far inset when adding the gas strut/piston on.*

*You can try removing the face panel and making it slightly less inset. If you have tried this and it does not improve your mattress is too light for our system. Please contact us and we can look at getting you weaker gas pistons made.*

*If your mattress is too light, it may be best to only use 1x hydraulic on the back left and the back right. If this is then well weighted you can proceed with adding more screws, if this still too heavy or too light please contact us about replacement gas pistons.*

*You can optionally remove the pistons in the meantime and place the mattress on it, to use it as a lowered bed.*

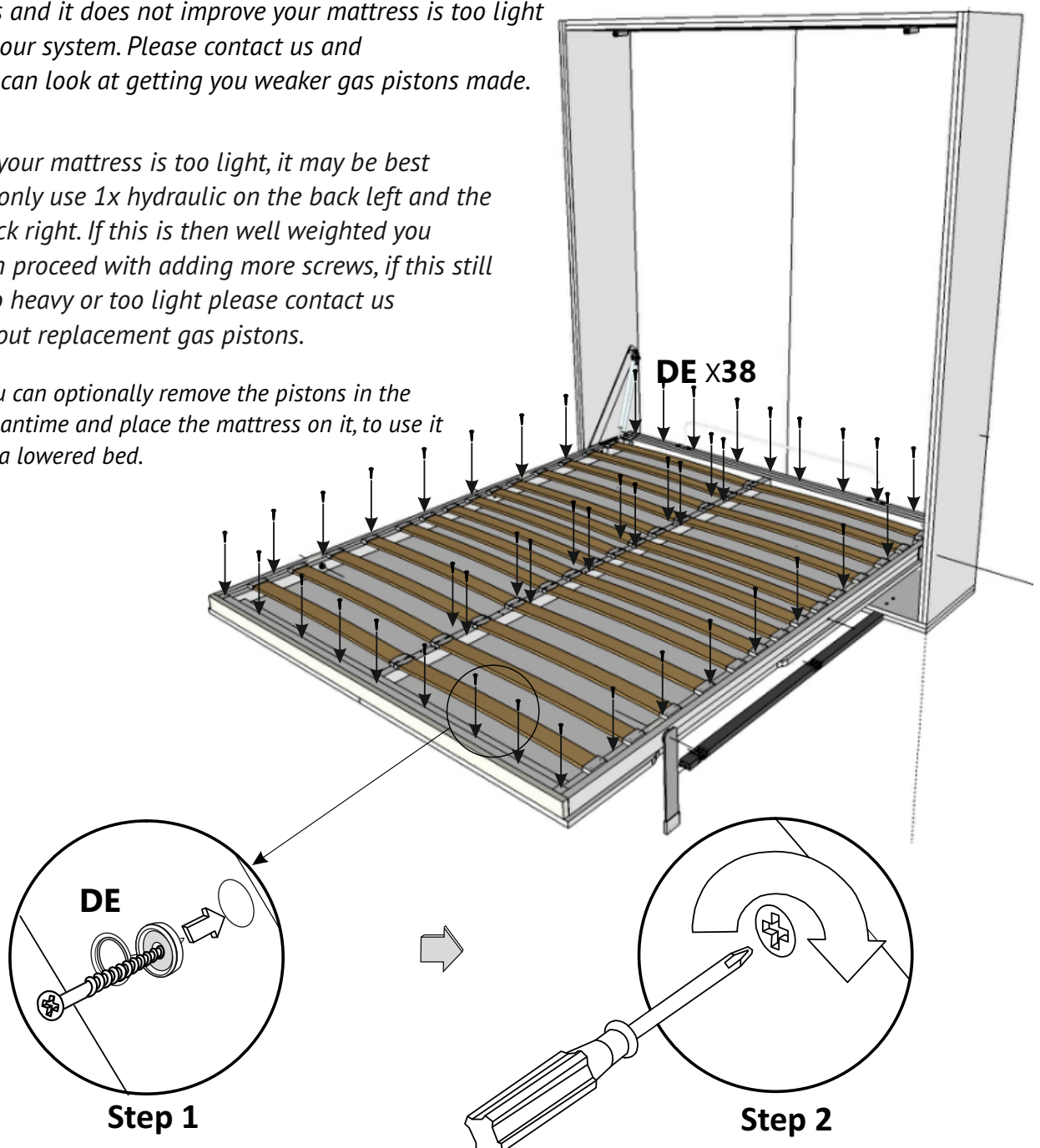

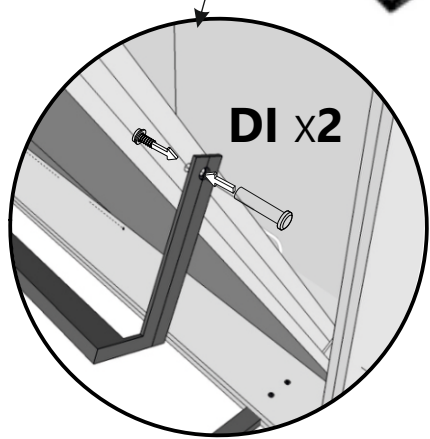
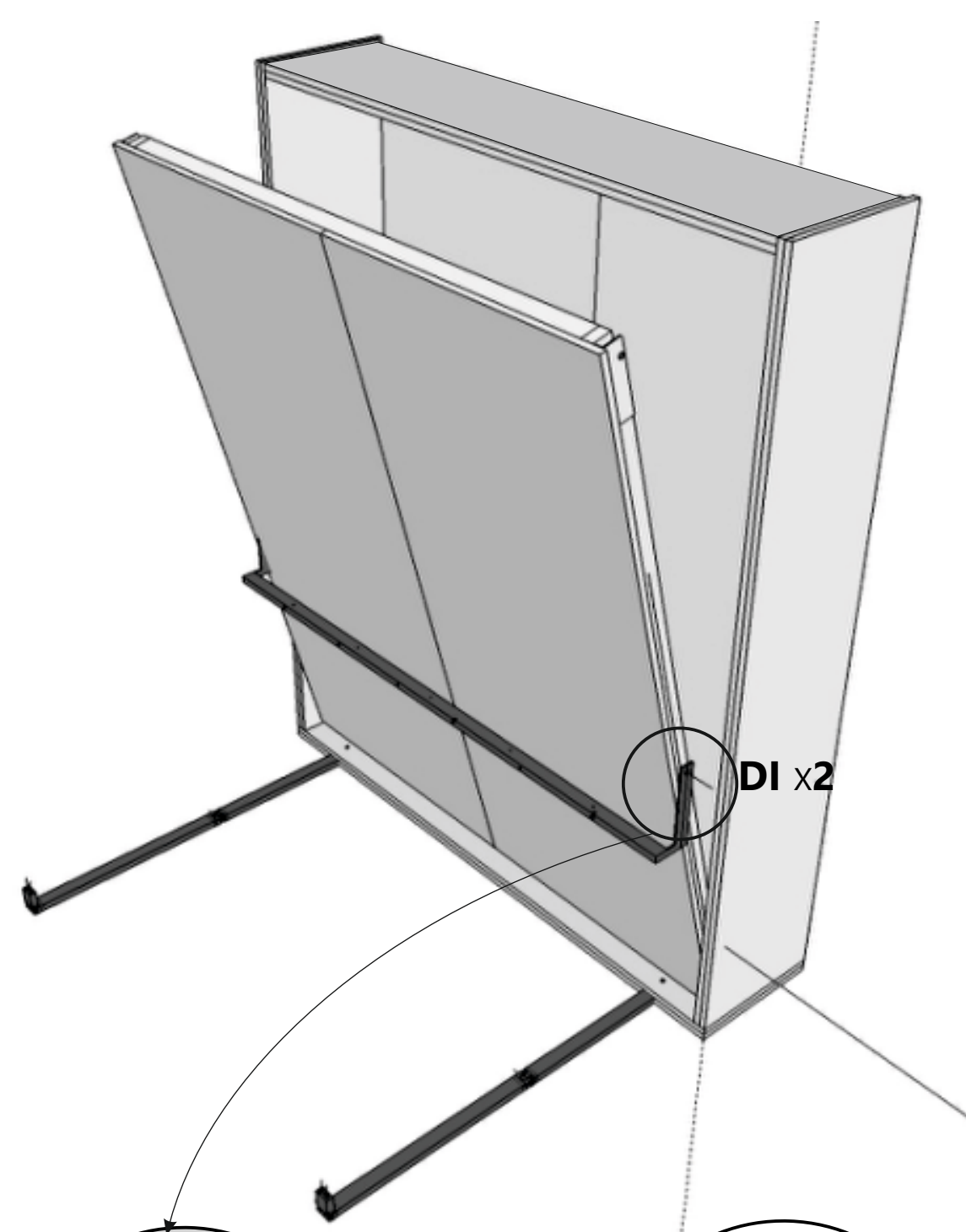

Step 1

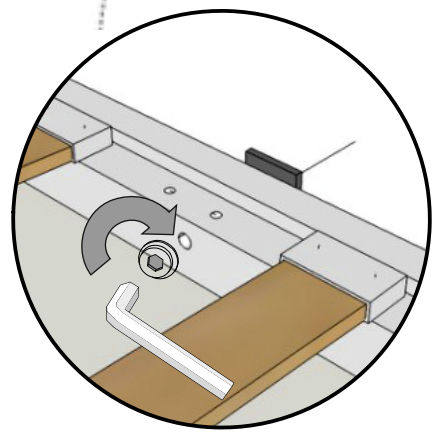

Step 2

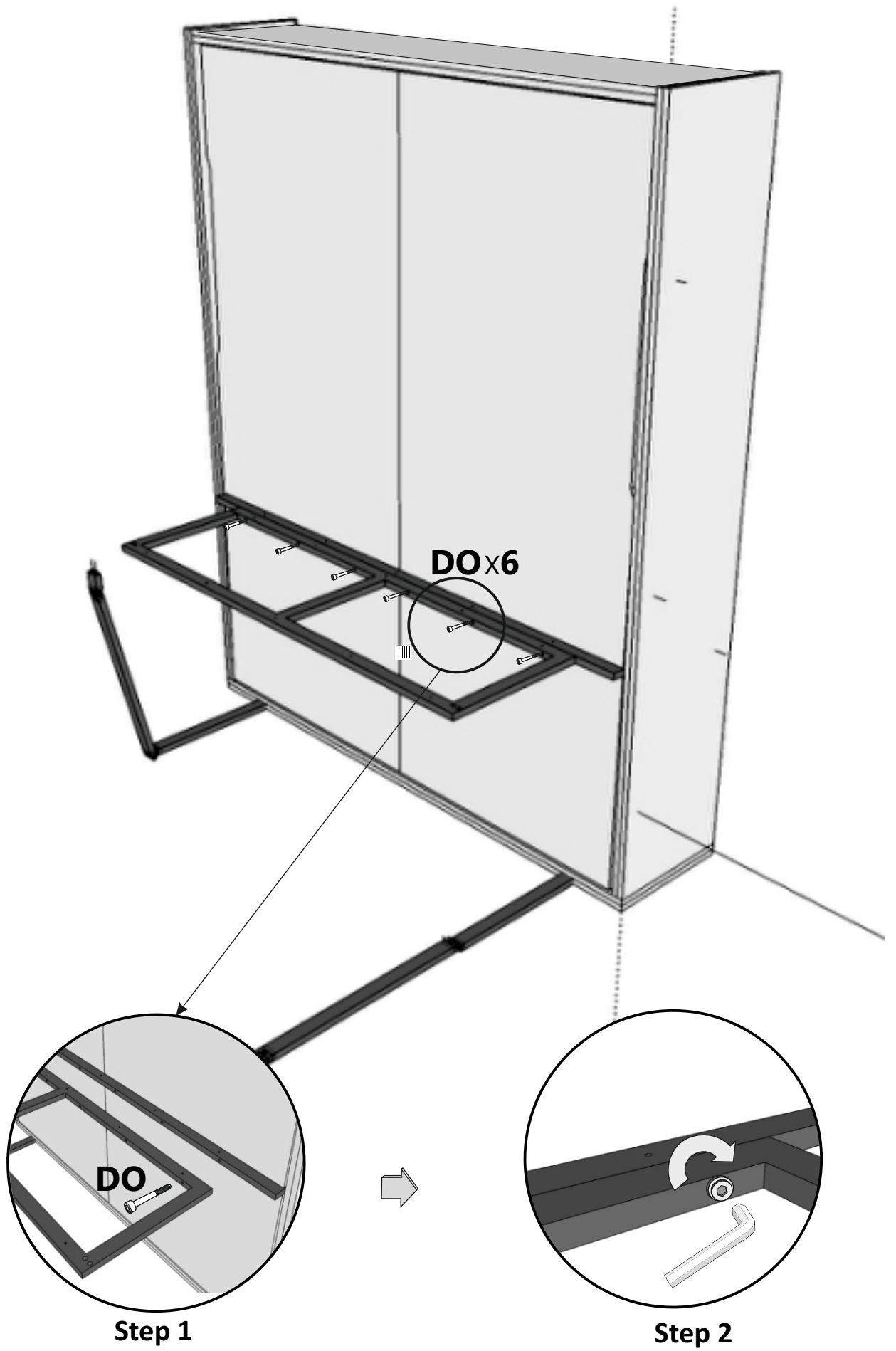



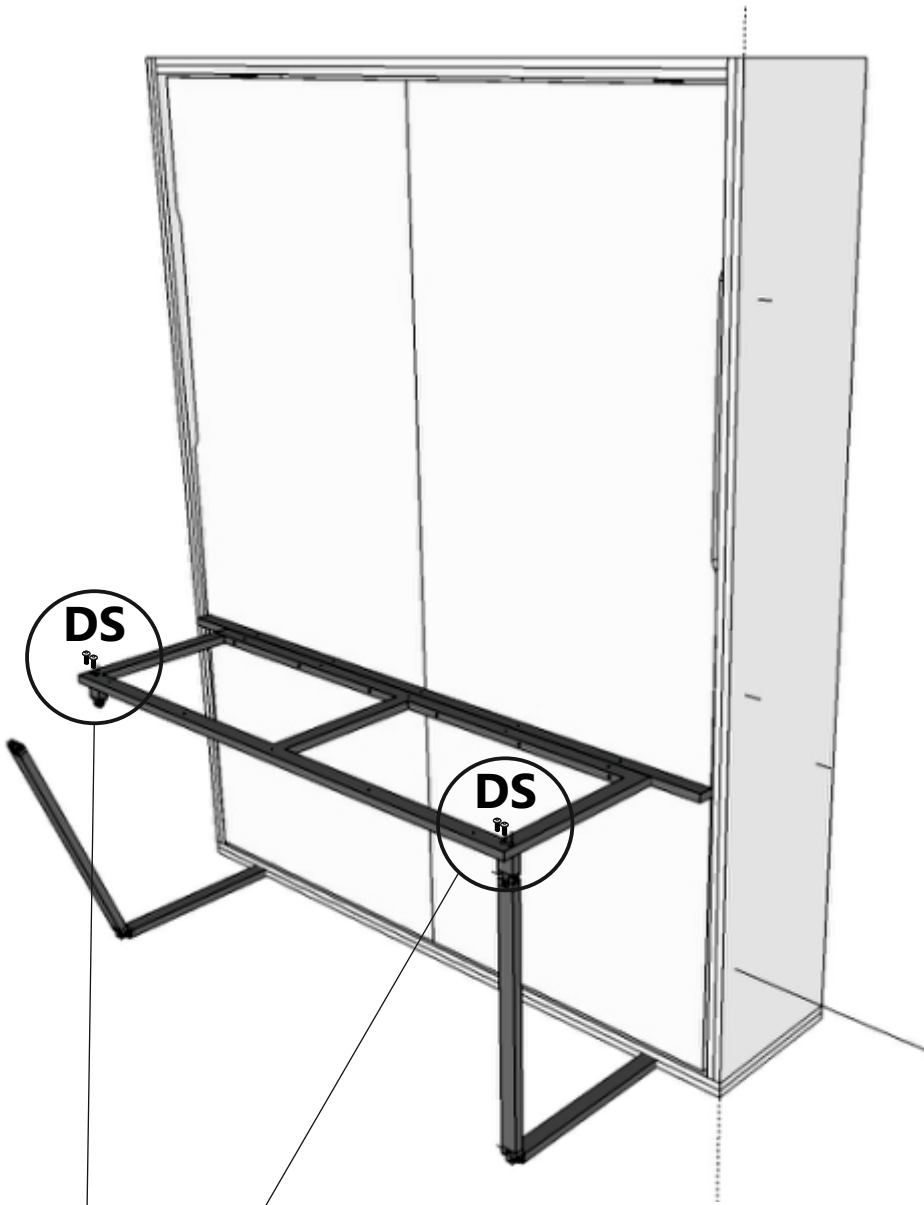

**DS x4**

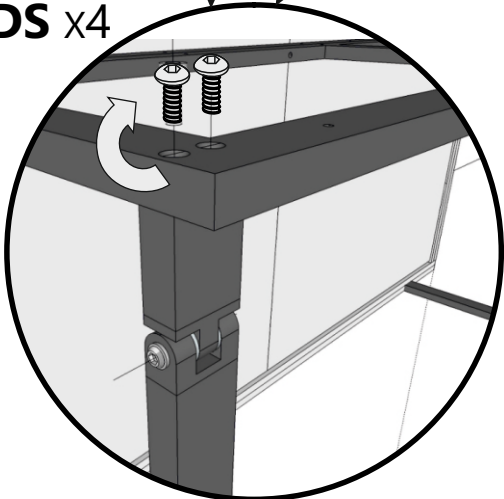

**Step 1**

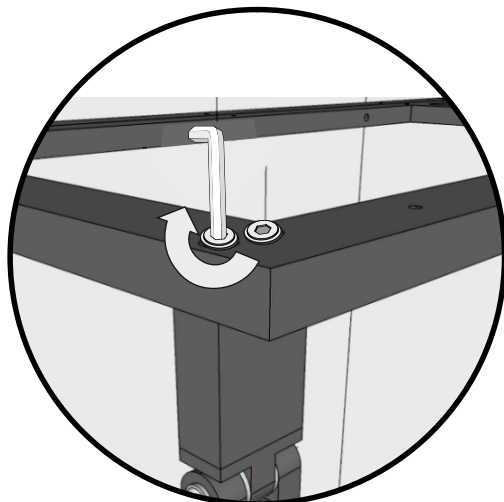

**Step 2**

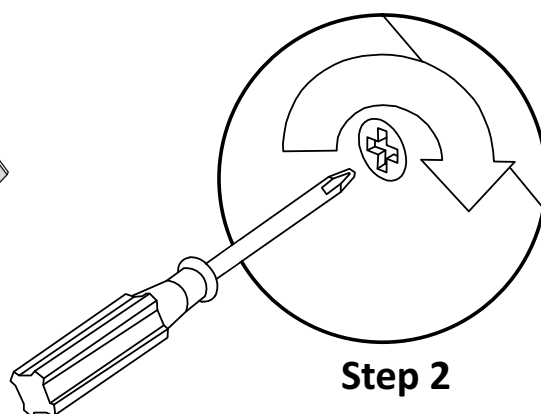
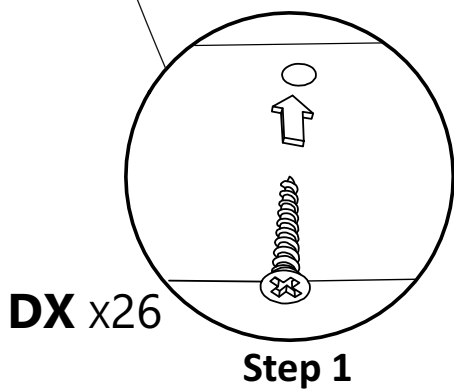
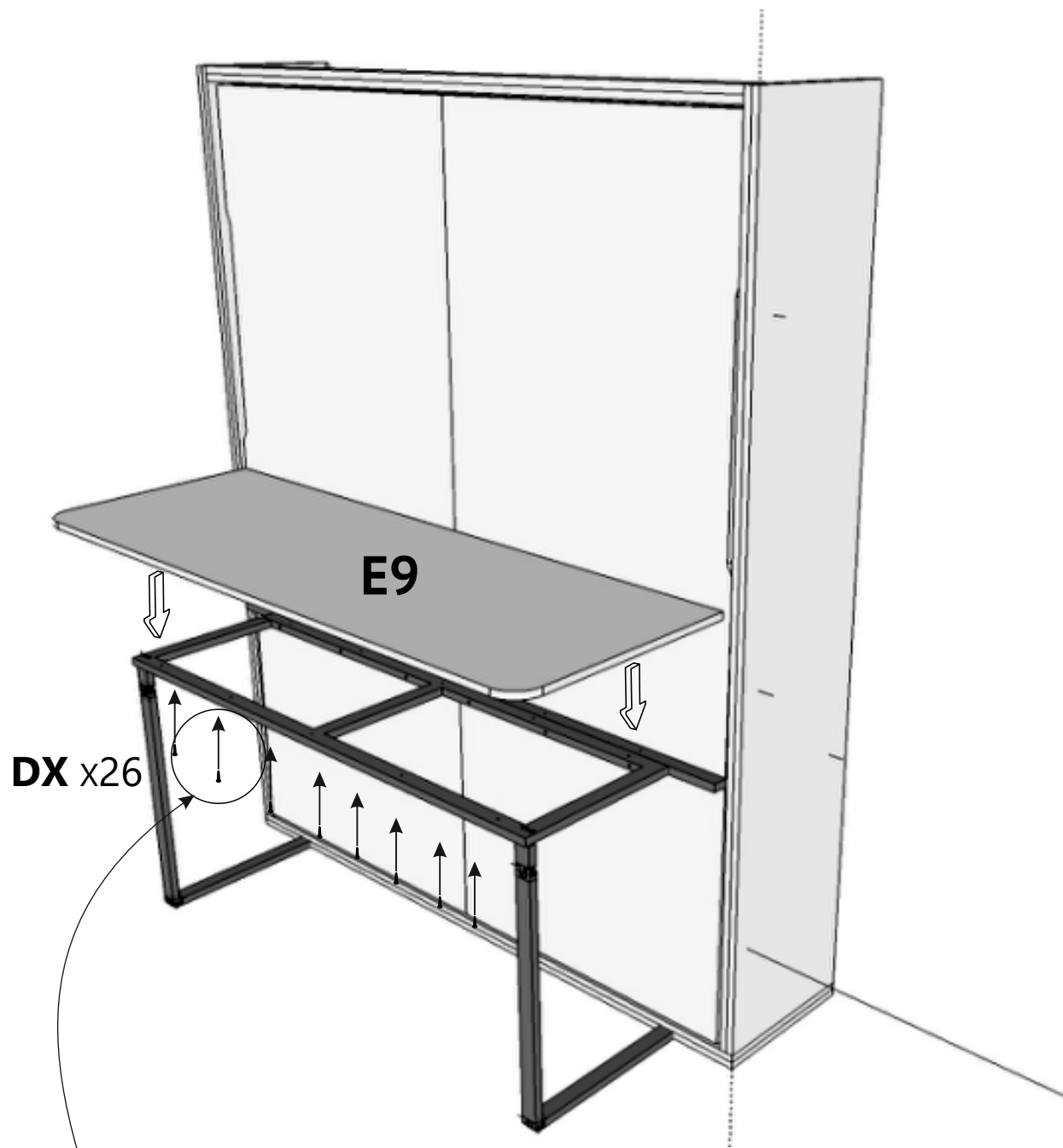

After you lower your frame with the face panel on it. You can place your mattress down. This will keep the bed down. You can now install the mattress holder.

Please make sure to follow the next step carefully. Do not skip securing the face panels!

